



# Installation Instruction

## Air conditioner

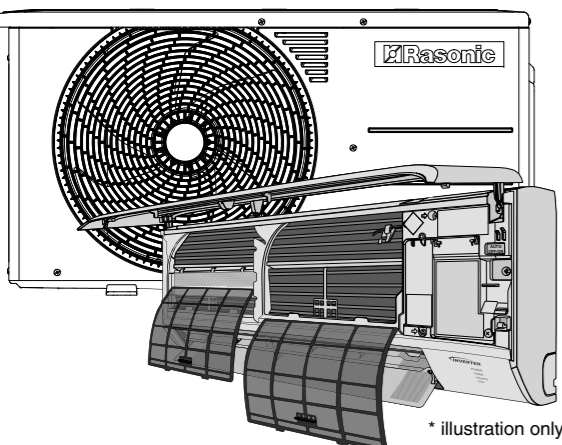

illustration only

MODEL NO : RS/RU-LZ9\*\* (1.0HP)  
RS/RU-LZ12\*\* (1.5HP)

**CAUTION**

**R32 REFRIGERANT**

This Air Conditioner contains and operates with refrigerant R32.

**THIS PRODUCT MUST ONLY BE INSTALLED OR SERVICED BY QUALIFIED PERSONNEL.**

Refer to National, State, Territory and local legislation, regulations, codes, installation & operation manuals, before the installation, maintenance and/or service of this product.

Explanation of symbols displayed on the indoor unit or outdoor unit.

	<b>WARNING</b>	This symbol shows that this equipment uses a mildly flammable refrigerant. If the refrigerant is leaked, together with an external ignition source, there is a possibility of ignition.
	<b>CAUTION</b>	This symbol shows that the Installation Manual should be read carefully.
	<b>CAUTION</b>	This symbol shows that a service personnel should be handling this equipment with reference to the Installation Manual.
	<b>CAUTION</b>	This symbol shows that there is information included in the Operation Manual and/or Installation Manual.

**SAFETY PRECAUTIONS**

- Read the following "SAFETY PRECAUTIONS" carefully before installation.
- Electrical work must be installed by a licensed electrician. Be sure to use the correct rating of the power plug and main circuit for the model to be installed.
- The caution items stated here must not be followed because these important contents are related to safety. The meaning of each indication used is as below. Incorrect installation due to ignoring of the instruction will cause harm or damage, and the seriousness is classified by the following indications.

	<b>WARNING</b>	This indication shows the possibility of causing death or serious injury.	The items to be followed are classified by symbols:		Symbol with white background denotes item that is PROHIBITED.
	<b>CAUTION</b>	This indication shows the possibility of causing injury or damage to properties only.			Symbol with dark background denotes item that must be carried out.

Carry out test running to confirm that no abnormality occurs after the installation. Then, explain to user the operation, care and maintenance as stated in instructions. Please remind the customer to keep the operating instructions for future reference.

If the equipment is transferred to a new user or delivered to a recycling plant, be sure also to hand over the manual.

**WARNING**

- Do not use means to accelerate the defrosting process or to clean, other than those recommended by the manufacturer. Any unit method or using incompatible material may cause product damage, burst and serious injury.
- Do not install outdoor unit near handrail of veranda. When installing air-conditioner unit on veranda of a high rise building, child may climb up to outdoor unit and cross over the handrail causing an accident.
- Do not use unspecified cord, modified cord, joint cord or extension cord for power supply cord. Do not share the single outlet with other electrical appliances. Poor contact, poor insulation or over current will cause electrical shock or fire.
- Do not tie up the power supply cord into a bundle by hand.
- Abnormal temperature rise on power supply cord may happen.
- Do not insert your fingers or other objects into the high speed rotating fan may cause injury.
- Do not sit or step on the unit, you may fall down accidentally.
- Keep plastic bags (packaging material) away from children, it may cling to nose and mouth and prevent breathing.
- When installing or relocating air conditioner, do not let any substance other than the specified refrigerant, eg. air etc. mix into refrigeration cycle (piping). Mixing of air etc. will cause abnormal high pressure in refrigeration cycle and result in explosion, injury etc.
- Do not pierce or burn as the appliance is pressurized. Do not expose the appliance to heat, flame, sparks, or other sources of ignition. Else, it may explode and cause injury or death.
- Do not add or replace refrigerant other than specified type. It may cause product damage, burst and injury etc.

**WARNING**

- For R32/R410A model, use piping, flare nut and tools which is specified for R32/R410A refrigerant. Using of existing (R22) piping, flare nut and tools may cause abnormally high pressure in the refrigeration cycle (piping), and possibly result in explosion and injury.
- For R32 and R410A, the same flare nut on the outdoor unit side and pipe can be used.
- Since with the working pressure for R32/R410A is higher than that of refrigerant R22 model, replacing conventional piping and flare nuts on the outdoor unit side are recommended.
- If reuse piping is unavoidable, refer to instruction "IN CASE OF REUSING EXISTING REFRIGERANT PIPING"
- Thickness of copper pipes used with R32/R410A must be more than 0.8 mm. Never use copper pipes thinner than 0.8 mm.
- It is desirable that the amount of residual oil less than 40 mg/10 m.
- Engage authorized dealer or specialist for installation.
- If installation done by the user is incorrect, it will cause water leakage, electrical shock or fire.
- For refrigeration system work, install according to this installation instructions strictly. If installation is defective, it will cause water leakage, electrical shock or fire.
- Use the attached accessories parts and specified parts for installation. Otherwise, it will cause the set to fall, water leakage, fire or electrical shock.
- Install at a strong and firm location which is able to withstand weight of the set. If the strength is not enough or installation is not properly done, the set will drop and cause injury.
- For electrical work, follow the national regulation, legislation and this installation instructions. An independent circuit and single outlet must be used. If electrical circuit capacity is not enough or defect found in the electrical work, it will cause electrical shock or fire.
- Do not use joint cable for indoor / outdoor connection cable. Use the specified indoor/outdoor connection cable, refer to instruction 5 "CONNECT THE CABLE TO THE INDOOR UNIT and connect tightly for indoor/outdoor connection. Clamp the cable so that no external force will have impact on the terminal. If connection or fixing is not perfect, it will cause heat up or fire at the connection.
- Wire routing must be properly arranged so that control board cover is fixed properly. If control board cover is not fixed perfectly, it will cause fire or electrical shock.
- This equipment is strongly recommended to be installed with Earth Leakage Circuit Breaker (ELCB) or Residual Current Device (RCD), with a rating of 30 mA at 1 sec or less. Otherwise, it may cause electrical shock and fire in case of equipment breakdown or insulation breakdown.
- During installation, install the refrigerant piping properly before running the compressor. Operation of compressor without fixing refrigeration piping and valves at opened position will cause suck-in of air, abnormal high pressure in refrigeration cycle and result in explosion, injury etc.
- During pump down operation, stop the compressor before removing the refrigeration piping. Removal of refrigeration piping while compressor is operating and valves are opened will cause suck-in of air, abnormal high pressure in refrigeration cycle and result in explosion, injury etc.
- Tighten the flare nut with torque wrench according to specified method. If the flare nut is over-tightened, after a long period, the flare may break and cause refrigerant gas leakage.
- After completion of installation, confirm there is no leakage of refrigerant gas. It may generate toxic gas when the refrigerant contacts with fire.
- Ventilate if there is refrigerant gas leakage during operation. It may cause toxic gas when the refrigerant contacts with fire.
- Be aware that refrigerants may not contain an odour.

**PRECAUTION FOR USING R32 REFRIGERANT**

- Pay careful attention to the following points and the installation work procedures.

**WARNING**

- The appliance shall be stored, installed and operated in a well ventilated room with indoor floor area larger than A<sub>min</sub> (m<sup>2</sup>) [refer Table A] and without any continuously operating ignition source. Keep away from open flames, any operating gas appliances or any operating electric heater. Else, it may explode and cause injury or death.
- The mixing of different refrigerants within a system is prohibited. Models that use refrigerant R32 and R410A have a different charging port thread diameter to prevent erroneous charging with refrigerant R22 and for safety.
- Therefore, check beforehand. [The charging port thread diameter for R32 and R410A is 12.7 mm (1/2 inch).]
- Ensure that foreign matter (oil, water, etc.) does not enter the piping.
- Also, when storing the piping, securely seal the opening by pinching, taping, etc. (Handling of R32 is similar to R410A.)
- Operation, maintenance, repairing and refrigerant recovery should be carried out by trained and certified personnel in the use of flammable refrigerants and as recommended by the manufacturer. Any personnel conducting an operation, servicing or maintenance on a system or associated parts of the equipment should be trained and certified.
- Any part of refrigerating circuit (evaporators, air coolers, AHU, condensers or liquid receivers) or piping should not be located in the proximity of heat sources, open flames, operating gas appliance or an operating electric heater.
- The user/owner or their authorized representative shall regularly check the alarms, mechanical ventilation and detectors, at least once a year, where as required by national regulations, to ensure their correct functioning.
- A logbook shall be maintained. The results of these checks shall be recorded in the logbook.
- In case of ventilations in occupied spaces shall be checked to confirm no obstruction.
- Before a new refrigerating system is put into service, the person responsible for placing the system in operation should ensure that trained and certified operating personnel are instructed on the basis of the instruction manual about the construction, supervision, operation and maintenance of the refrigerating system, as well as the safety measures to be observed, and the properties and handling of the refrigerant used.
- The general requirement of trained and certified personnel are indicated as below:
  - Knowledge of legislation, regulations and standards relating to flammable refrigerants; and,
  - Detailed knowledge of and skills in handling flammable refrigerants, personal protective equipment, refrigerant leakage prevention, handling of cylinders, charging, leak detection, recovery and disposal; and,
  - Able to understand and to apply in practice the requirements in the national legislation, regulations and Standards; and,
  - Continuously undergo regular and further training to maintain this expertise.
- Air-conditioner piping in the occupied space shall be installed in such a way to protect against accidental damage in operation and service.
- Precautions shall be taken to avoid excessive vibration or pulsation to refrigerating piping.
- Ensure protection devices, refrigerating piping and fittings are well protected against adverse environmental effects (such as the danger of water collecting and freezing in relief pipes or the accumulation of dirt and debris).
- Expansion and contraction of long runs piping in refrigerating systems shall be designed and installed securely (mounted and guarded) to minimize the likelihood hydraulic shock damaging the system.
- Protect the refrigerating system from accidental rupture due to moving furniture or reconstruction activities.
- To ensure no leaking, field-made refrigerant joints indoors shall be tightness tested. The test method shall have a sensitivity of 5 grams per year of refrigerant or better under a pressure of at least 0.25 times the maximum allowable pressure (>1.04MPa, max 4.15MPa). No leak shall be detected.

**2-10. Checks to electrical devices**

- Repair and maintenance to electrical components shall include initial safety checks and component inspection procedures.
- Initial safety checks shall include but not limit to:-
  - That capacitors are discharged; this shall be done in a safe manner to avoid possibility of sparking.
  - That there is no live electrical components and wires are exposed while charging, recovering or purging the system.
  - That there is continuity of earth bonding.
- At all times the manufacturer's maintenance and service guidelines shall be followed.
- In if doubt consult the manufacturer's technical department for assistance.
- If a fault exists that could compromise safety, then no electrical supply shall be connected to the circuit until it is satisfactorily dealt with.
- If the fault cannot be corrected immediately but it is necessary to continue operation, an adequate temporary solution shall be used.
- The owner of the equipment must be informed or reported so all parties are advised thereinafter.

**3. Repairs to sealed components**

- During repairs to sealed components, all electrical supplies shall be disconnected from the equipment being worked upon prior to any removal of sealed covers, etc.
- It is absolutely necessary to have an electrical supply to equipment during servicing, then a permanently operating form of leak detection shall be located at the most critical point to warn of a potentially hazardous situation.
- Particular attention shall be paid to the following to ensure that by working on electrical components, the casing is not altered in such a way that the level of protection is affected. This shall include damage to cables, excessive number of connectors, terminals not made to original specification, damage to seals, incorrect fitting of glands, etc.
- Ensure that apparatus is mounted securely.
- Ensure that seals or sealing materials have not degraded such that they no longer serve the purpose of preventing the ingress of flammable atmospheres.
- Replacement parts shall be in accordance with the manufacturer's specifications.

NOTE: - The use of silicon sealant may inhibit the effectiveness of some types of leak detection equipment. Intrinsically safe components do not have to be isolated prior to working on them.

**4. Repair to intrinsically safe components**

- Do not apply any permanent inductive or capacitance loads to the circuit without ensuring that this will not exceed the permissible voltage and current permitted for the equipment in use.
- Intrinsically safe components are the only types that can be worked on while live in the presence of a flammable atmosphere.
- The test apparatus shall be at the correct rating.
- Replace components only with parts specified by the manufacturer. Unspecified parts by manufacturer may result ignition of refrigerant in the atmosphere from a leak.

**5. Cabling**

- Check that cabling will not be subject to wear, corrosion, excessive pressure, vibration, sharp edges or any other adverse environmental effects.
- The check shall also take into account the effects of aging or continual vibration from sources such as compressors or fans.

**6. Detection of flammable refrigerants**

- Under no circumstances shall potential sources of ignition be used in the searching or detection of refrigerant leaks.
- A halide torch (or any other detector using a naked flame) shall not be used.
- The following leak detection methods are acceptable for all refrigerant systems.
  - No leaks shall be detected when using detection equipment with a sensitivity of 5 grams per year of refrigerant or better under a pressure of at least 0.25 times the maximum allowable pressure (>1.04MPa, max 4.15MPa) for example, a universal sniffer.
  - Electronic leak detectors may be used to detect flammable refrigerants, but the sensitivity may not be adequate, or may need re-calibration. (Detection equipment shall be calibrated in a refrigerant-free area.)
- Ensure that the detector is not a potential source of ignition and is suitable for the refrigerant used.
- Leak detection equipment shall be set at a percentage of the LFL of the refrigerant and shall be calibrated to the refrigerant employed and the appropriate percentage of gas (25 % maximum) is confirmed.
- Leak detection fluids are also suitable for use with most refrigerants, for example, bubble method and fluorescent method pipes-work. The use of detergents containing chlorine shall be avoided as the chlorine may react with the refrigerant and corrode the copper pipe-work.
- If a leak is suspected, all naked flames shall be removed/extinguished.
- If a leakage of refrigerant is found which requires brazing, all of the refrigerant shall be recovered from the system, or isolated (by means of shut off valves) in a part of the system remote from the leak. The precautions in #7 must be followed to remove the refrigerant.

**7. Removal and evacuation**

- When breaking into the refrigerant circuit to make repairs – or for any other purpose – conventional procedures shall be used. However, it is important that best practice is followed since flammability is a consideration. The following procedure shall be adhered to:
  - remove refrigerant -> purge the circuit with inert gas -> evacuate -> purge with inert gas -> open the circuit by cutting or brazing
- The refrigerant charge shall be recovered into the correct recovery cylinders.
- The system shall be purged with OFN to render the appliance safe. (remark: OFN = oxygen free nitrogen, type of inert gas) This process may need to be repeated several times.
- Compressed air or oxygen shall not be used for this task.
- Purging shall be achieved by breaking the vacuum in the system with OFN and continuing to fill until the working pressure is achieved, then venting to atmosphere, and finally pulling down to a vacuum.
- This process shall be repeated until no refrigerant is within the system.
- When the final OFN charge is used, the system shall be vented down to atmospheric pressure to enable work to take place.
- This operation is absolutely vital if brazing operations on the pipe work are to take place.
- Ensure that the outlet for the vacuum pump is not close to any potential ignition sources and there is ventilation available.

**8. Charging procedures**

- In addition to conventional charging procedures, the following requirements shall be followed.
  - Ensure that contamination of different refrigerants does not occur when using charging equipment.
  - Hoses or lines shall be as short as possible to minimize the amount of refrigerant contained in them.
  - Cylinders shall be kept in an appropriate position according to the instructions.
  - Ensure that the refrigerating system is earthed prior to charging the system with refrigerant.
  - Label the system when charging is complete (if not already).
  - Extreme care shall be taken not to over fill the refrigerating system.
- Prior to recharging the system it shall be pressure tested with OFN (refer to #7).
- The system shall be leak tested on completion of charging and prior to commissioning.
- A follow up leak test shall be carried out prior to leaving the site.
- Electrostatic charge may accumulate and create a hazardous condition when charging and discharging the refrigerant. To avoid fire or explosion, dissipate static electricity during transfer by grounding and bonding containers and equipment before charging/ discharging.

**9. Decommissioning**

- Before carrying out this procedure, it is essential that the technician is completely familiar with the equipment and all its details.
- It is recommended good practice that all refrigerants are recovered safely.
- Prior to the task being carried out, an oil and refrigerant sample shall be taken in case analysis is required prior to re-use of recovered refrigerant.
- It is essential that electrical power is available before the task is commenced.
  - Become familiar with the equipment and its operation.
  - Isolate system electrically.
- Before attempting the procedure ensure that:
  - mechanical handling equipment is available, if required, for handling refrigerant cylinders;
  - all personal protective equipment is available and being used correctly;
  - the recovery process is supervised at all times by a competent person;
  - recovery equipment and cylinders conform to the appropriate standards.
- Pump down refrigerant system, if possible.
- If a vacuum is not possible, make a manifold so that refrigerant can be removed from various parts of the system.
- Make sure that cylinder is situated on the scales before recovery takes place.
- Start the recovery machine and operate in accordance with instructions.
- Do not over fill cylinders. (No more than 80 % volume liquid charge).
- Do not exceed the maximum working pressure of the cylinder, even temporarily.
- When the cylinders have been filled correctly and the process completed, make sure that the cylinders and the equipment are removed from site promptly and all isolation valves on the equipment are closed off.
- Recovered refrigerant shall not be charged into another refrigerating system unless it has been cleaned and checked.
- Electrostatic charge may accumulate and create a hazardous condition when charging or discharging the refrigerant. To avoid fire or explosion, dissipate static electricity during transfer by grounding and bonding containers and equipment before charging/ discharging.

**10. Labelling**

- Equipment shall be labelled stating that it has been de-commissioned and emptied of refrigerant.
- The label shall be dated and signed.
- Ensure that there are labels on the equipment stating the equipment contains flammable refrigerant.

**11. Recovery**

- When removing refrigerant from a system, either for servicing or decommissioning, it is recommended good practice that all refrigerants are removed safely.
- When transferring refrigerant into cylinders, ensure that only appropriate refrigerant recovery cylinders are employed.
- Ensure that the correct number of cylinders for holding the total system charge are available.
- All cylinders to be used are designated for the recovered refrigerant and labelled for that refrigerant (i.e. special cylinders for the recovery of refrigerant).
- Cylinders shall be complete with pressure relief valve and associated shut-off valves in good working order.
- Recovery cylinders are evacuated and, if possible, cooled before recovery occurs.
- The recovery equipment shall be in good working order with a set of instructions concerning the equipment that is at hand and shall be suitable for the recovery of concerning the equipment that is at hand and shall be suitable for the recovery of flammable refrigerants.
- In addition, a set of calibrated weighing scales shall be available and in good working order.
- Hoses shall be complete with leak-free disconnect couplings and in good condition.
- Before using the recovery machine, check that it is in satisfactory working order, has been properly maintained and that any associated electrical components are sealed to prevent ignition in the event of a refrigerant release.
- Consult manufacturer if in doubt.
- The recovered refrigerant shall be returned to the refrigerant supplier in the correct recovery cylinder, and the relevant Waste Transfer Note arranged.
- Do not mix refrigerants in recovery units and especially not in cylinders.
- If compressors or compressor oils are to be removed, ensure that they have been evacuated to an acceptable level to make certain that flammable refrigerant does not remain within the lubricant.
- The evacuation process shall be carried out prior to returning the compressor to the suppliers.
- Only electric heating to the compressor body shall be employed to accelerate this process.
- When oil is drained from a system, it shall be carried out safely.

**Required tools for Installation Works**

1 Phillips screw driver	6 Pipe cutter	11 Thermometer	16 Torque wrench
2 Level gauge	7 Reamer	12 Megameter	18 Nmm (1.8 kgf*cm)
3 Electric drill, hole core drill (ø70 mm)	8 Knife	13 Multimeter	42 Nmm (4.3 kgf*cm)
4 Hexagonal wrench (4 mm)	9 Gas leak detector	14 Vacuum pump	55 Nmm (5.6 kgf*cm)
5 Spanner	10 Measuring tape	15 Gauge manifold	65 Nmm (6.6 kgf*cm)
			100 Nmm (10.2 kgf*cm)

**CAUTION**

- This equipment must be properly earthed. Earth line must not be connected to gas pipe, water pipe, earth of lightning rod and telephone. Otherwise, it may cause electrical shock in case of equipment breakdown or insulation breakdown.

**CAUTION**

- Do not install the unit in a place where leakage of flammable gas may occur. In case gas leaks and accumulates at surrounding of the unit, it may cause fire.
- Prevent liquid or vapor from entering sumps or sewers since vapor is heavier than air and may form suffocating atmospheres.
- Do not release refrigerant during piping work for installation, re-installation and during repairing refrigeration parts. Take care of the liquid refrigerant, it may cause frostbite.
- Do not install this appliance in a laundry room or other location where water may drip from the ceiling, etc.
- Do not touch the sharp aluminium fin, sharp parts may cause injury.

Carry out drainage piping as mentioned in installation instructions. If drainage is not perfect, water may enter the room and damage the furniture.

Select an installation location which is easy for maintenance. Incoerc installation, service or repair of this air conditioner may increase the risk of rupture and this may result in loss damage or injury and/or property.

Power supply connection to the room air conditioner.

Use power supply cord 3 x 1.5 mm<sup>2</sup> (1.0 – 1.5HP), type designation 60245 IEC 57 or heavier cord.

Connect the power supply cord to the mains using one of the following method.

Power supply point should be in easily accessible place for power disconnection in case of emergency.

- In some countries, permanent connection of this air conditioner to the power supply is prohibited.
  - Power supply connection to the receptacle using power plug.
  - Use an approved 15/16 A (1.0 – 1.5HP) power plug with earth pin for the connection to the socket.
- Power supply connection to a circuit breaker for the permanent connection.
  - Use an approved 16 A (1.0 – 1.5HP) circuit breaker for the permanent connection. It must be a double pole switch with a minimum 3.0 mm contact gap.

Installation work. It may need two people to carry out the installation work.

- Keep any required ventilation openings clear of obstruction.

**PRECAUTION FOR USING R32 REFRIGERANT**

- Pay careful attention to the following points and the installation work procedures.

**WARNING**

- The appliance shall be stored, installed and operated in a well ventilated room with indoor floor area larger than A<sub>min</sub> (m<sup>2</sup>) [refer Table A] and without any continuously operating ignition source. Keep away from open flames, any operating gas appliances or any operating electric heater. Else, it may explode and cause injury or death.
- The mixing of different refrigerants within a system is prohibited. Models that use refrigerant R32 and R410A have a different charging port thread diameter to prevent erroneous charging with refrigerant R22 and for safety.
- Therefore, check beforehand. [The charging port thread diameter for R32 and R410A is 12.7 mm (1/2 inch).]
- Ensure that foreign matter (oil, water, etc.) does not enter the piping.
- Also, when storing the piping, securely seal the opening by pinching, taping, etc. (Handling of R32 is similar to R410A.)
- Operation, maintenance, repairing and refrigerant recovery should be carried out by trained and certified personnel in the use of flammable refrigerants and as recommended by the manufacturer. Any personnel conducting an operation, servicing or maintenance on a system or associated parts of the equipment should be trained and certified.
- Any part of refrigerating circuit (evaporators, air coolers, AHU, condensers or liquid receivers) or piping should not be located in the proximity of heat sources, open flames, operating gas appliance or an operating electric heater.
- The user/owner or their authorized representative shall regularly check the alarms, mechanical ventilation and detectors, at least once a year, where as required by national regulations, to ensure their correct functioning.
- A logbook shall be maintained. The results of these checks shall be recorded in the logbook.
- In case of ventilations in occupied spaces shall be checked to confirm no obstruction.
- Before a new refrigerating system is put into service, the person responsible for placing the system in operation should ensure that trained and certified operating personnel are instructed on the basis of the instruction manual about the construction, supervision, operation and maintenance of the refrigerating system, as well as the safety measures to be observed, and the properties and handling of the refrigerant used.
- The general requirement of trained and certified personnel are indicated as below:
  - Knowledge of legislation, regulations and standards relating to flammable refrigerants; and,
  - Detailed knowledge of and skills in handling flammable refrigerants, personal protective equipment, refrigerant leakage prevention, handling of cylinders, charging, leak detection, recovery and disposal; and,
  - Able to understand and to apply in practice the requirements in the national legislation, regulations and Standards; and,
  - Continuously undergo regular and further training to maintain this expertise.
- Air-conditioner piping in the occupied space shall be installed in such a way to protect against accidental damage in operation and service.
- Precautions shall be taken to avoid excessive vibration or pulsation to refrigerating piping.
- Ensure protection devices, refrigerating piping and fittings are well protected against adverse environmental effects (such as the danger of water collecting and freezing in relief pipes or the accumulation of dirt and debris).
- Expansion and contraction of long runs piping in refrigerating systems shall be designed and installed securely (mounted and guarded) to minimize the likelihood hydraulic shock damaging the system.
- Protect the refrigerating system from accidental rupture due to moving furniture or reconstruction activities.
- To ensure no leaking, field-made refrigerant joints indoors shall be tightness tested. The test method shall have a sensitivity of 5 grams per year of refrigerant or better under a pressure of at least 0.25 times the maximum allowable pressure (>1.04MPa, max 4.15MPa). No leak shall be detected.

**Attached accessories**

No.	Accessories part	Qty.	No.	Accessories part	Qty.
1	Installation plate	1	6	Remote control holder fixing screw	2
2	Installation plate fixing screw	5	7	Drain pan	1
3	Remote Control	1	8	Drain elbow	1
4	Battery	2			
5	Remote control holder	1			

**Applicable piping kit**

Piping size	Gas		Liquid	
	Ø	Length (m)	Ø	Length (m)
CZ-3F5, 7BP	9.52 mm (3/8")	6.35 mm (1/4")	6.35 mm (1/4")	6.35 mm (1/4")
CZ-4F5, 7, 10BP	12.7 mm (1/2")	6.35 mm (1/4")	6.35 mm (1/4")	6.35 mm (1/4")

Accessories: Flaring piping kit CZ-4F5, 7, 10AN

**SELECT THE BEST LOCATION**

**INDOOR UNIT**

- Do not install the unit in excessive oil fume area such as kitchen, workshop and etc.
- There should not be any heat source or steam near the unit.
- There should not be any obstacles blocking the air circulation.
- A place where air circulation in the room is good.
- A place where drainage can be easily done.
- A place where noise prevention is taken into consideration.
- Do not install the unit near the door way.
- Ensure the spaces indicated by arrows from the wall, ceiling, fence or other obstacles.
- Indoor unit of this air conditioner shall be installed in a height of at least 1.8 m.

**OUTDOOR UNIT**

- If an awning is built over the unit to prevent direct sunlight or rain, be careful that heat radiation from the condenser is not obstructed.
- There should not be any animal or plant which could be affected by hot air discharged.
- Keep the spaces indicated by arrows from wall, ceiling, fence or other obstacles.
- Do not place any obstacles which may cause a short circuit of the discharged air.
- If piping length is over the [piping length for additional gas], additional refrigerant should be added as shown in the (Table A).

**Table A**

Model	Capacity W (HP)	Piping size Gas	Piping size Liquid	Std. Length (m)	Max. Elevation (m)	Min. Piping Length (m)	Max. Piping Length (m)	Additional Refrigerant (g/m)	Piping Length for add. gas (m)	Max. Refrigerant Charge (kg)	A <sub>min</sub> (m <sup>2</sup> )
LZ9**	1.0HP	9.52 mm (3/8")	6.35 mm (1/4")	5	1	15	10	7.5	0.68		Not applicable (*)
LZ12**	1.5HP	12.7 mm (1/2")	6.35 mm (1/4")	5	1	15	15	7.5	0.95		Not applicable (*)

Example: For LZ9\*\*  
If the unit is installed at 10 m distance, the quantity of additional refrigerant should be => 10 m (distance) - 7.5 m (piping length for additional gas) => 2.5 m x 10 g/m (additional Refrigerant) => [25 g]

$A_{min} = (m_r / ((2.5 \times (LFL)^{0.6} \times h_r)) )^2$  \*\* not less than safety factor margin

$m_r$  = Refrigerant minimum room area, in m<sup>2</sup>  
 $LFL$  = Lower flammability limit (0.307 kg/m<sup>3</sup>)  
 $h_r$  = Installation height of the appliance (1.8 m for wall mounted)  
 $SF$  = Safety factor with a value of 0.75

The required minimum room area, shall also be governed by the safety factor margin formula below:  
 $A_{min} = m_r / (SF \times LFL \times h_r)$  The higher value shall be taken when determining the room area.

(\*)=> Systems with total refrigerant charge, m<sub>r</sub> lower than 1.84 kg are not subjected to any room area requirements.

If it is advisable to avoid more than 2 blockage directions for better ventilation.  
 For installation with 3 wall blockage (top, left & right), ensure the distance to unit for either left side or top side must be 200 mm or more.

More than 200 mm

More than 100 mm

More than 50 mm

More than 100 mm

Front View

- For any above installation patterns, either, left side or top side must be 200 mm or more.

**CAUTION**

**1. General**

- Must ensure the installation of pipe-work shall be kept to a minimum. Avoid use dented pipe and do not allow acute bending.
- Ensure that the piping work is done in accordance with physical safety and health regulations.
- Must comply with national gas regulations, state municipal rules and legislation.
- Notify relevant authorities in accordance with all applicable regulations.
- Must ensure mechanical connections be accessible for maintenance purposes.
- In cases that require mechanical ventilation, ventilation openings shall be kept clear of obstruction.
- When disposal of the product, do follow to the precautions in #11 and comply with national regulations.
- In case of field charge, the effect on refrigerant charge caused by the different pipe length has to be quantified, measured and labelled. Always contact local municipal offices for proper handling.
- Ensure the actual refrigerant charge is in accordance with the room size within which the refrigerant containing parts are installed.
- Ensure refrigerant charge not to leak.
- Wear appropriate protective equipment, including respiratory protection, as conditions warrant.
- Keep all sources of ignition and hot metal surfaces away.

**2. Servicing**

**2-1. Qualification of workers**

- Any qualified person who is involved with working on or breaking into a refrigerant circuit should hold a current valid certificate from an industry-accredited assessment authority, which authorizes their competence to handle refrigerants safely in accordance with an industry recognized ventilation, ventilation openings shall be kept clear of obstruction.
- Servicing shall only be performed as recommended by the equipment manufacturer. Maintenance and repair requiring the assistance of other skilled personnel shall be carried out under the supervision of the person competent in the use of flammable refrigerants.
- Servicing shall be performed only as recommended by the manufacturer.
- The system is inspected, regularly supervised and maintained by a trained and certified service personnel who is employed by the person user or party responsible.

**2-2. Checks to the area**

- Prior to beginning work on systems containing flammable refrigerants, safety checks are necessary to ensure that the risk of ignition is minimized.
- For repair to the refrigerating system, the precautions in #2-3 to #2-7 must be followed before conducting work on the system.

**2-3. Work procedure**

- Work shall be undertaken under a controlled procedure so as to minimize the risk of a flammable gas or vapour being present while the work is being performed.

**2-4. General work area**

- All maintenance staff and others working in the local area shall be instructed and supervised on the nature of work being carried out.
- Avoid working in confined spaces. Always ensure away from source, at least 2 meter of safety distance, or zoning of free space area of at least 2 meter in radius.

**2-5. Checking for presence of refrigerant**

- The area shall be checked with an appropriate refrigerant detector prior to work, to ensure the technician is aware of potentially flammable atmospheres.
- Ensure that the leak detection equipment being used is suitable for use with flammable refrigerants, i.e. non sparking, adequately sealed or intrinsically safe.
- In case of leakage/spillage happened, immediately ventilate area and stay upwind and away from spill/release.
- In case of leakage/spillage happened, do notify persons down wind of the leaking/spill, isolate immediate hazard area and keep unauthorized personnel out.

**2-6. Presence of fire extinguisher**

- If any hot work is to be conducted on the refrigerating equipment or any associated parts, appropriate fire extinguishing equipment shall be available at hand.
- Have a dry powder or CO<sub>2</sub> fire extinguisher adjacent to the charging area.

**2-7. No ignition sources**

- No person carrying out work in relation to a refrigerating system which involves exposing any pipe work that contains or has contained flammable refrigerant shall use any sources of ignition in such a manner that it may lead to the risk of fire or explosion. He/She must not be smoking when carrying out such work.
- All possible ignition sources, including cigarette smoking, should be kept sufficiently far away from the site of installation.
- In an indirect refrigeration circuit, if being used, the secondary circuit shall be checked for the presence of refrigerant.
- Prior to work taking place, the area around the equipment is to be surveyed to make sure that there are no flammable hazards or ignition risks.
- "No Smoking" signs shall be displayed.

**2-8. Ventilated area**

- Ensure that the area is in the open or that it is adequately ventilated before breaking into the system or conducting any hot work.
- A degree of ventilation shall continue during the period that the work is carried out.
- The ventilation should safely disperse any released refrigerant and preferably expel it externally into the atmosphere.

**2-9. Checks to the refrigerating equipment**

- Where electrical components are being changed, they shall be fit for the purpose and to the correct specification.
- At all times the manufacturer's maintenance and service guidelines shall be followed.
- If in doubt consult the manufacturer's technical department for assistance.
- The following checks shall be applied to installations using flammable refrigerants.
  - The actual refrigerant charge is in accordance with the room size within which the refrigerant containing parts are installed.
  - The ventilation machinery and outlets are operating adequately and are not obstructed.
  - In an indirect refrigeration circuit, if being used, the secondary circuit shall be checked for the presence of refrigerant.
  - Marking to the equipment continues to be visible and legible. Markings and signs that are illegible shall be corrected.
  - Refrigerating pipe or components are installed in a position where they are unlikely to be exposed to any substance which may corroded refrigerant containing components, unless the components are constructed of materials which are inherently resistant to being corroded or are properly protected against being so corroded.

**Indoor/Outdoor Unit Installation Diagram**

Length of power supply cord

- About 650 mm
- About 1550 mm

Piping direction

Right Right Right Right  
Left Left Left Left  
Rear Rear Rear Rear  
Left bottom Left bottom Left bottom Left bottom

Attention not to bend up drain hose

(+) Holder at the rear of

### 1 SELECT THE BEST LOCATION (Refer to "Select the best location" section)

### 2 HOW TO FIX INSTALLATION PLATE

The mounting wall shall be strong and solid enough to prevent it from vibration.

Dimension					
1	2	3	4	5	6
465 mm	70 mm (+)	365 mm	415 mm	10 mm	70 mm

• The center of installation plate should be at more than ① at right and left of the wall.  
 • The distance from installation plate edge to ceiling should more than ②.  
 • From installation plate center to unit's left side is ③.  
 • From installation plate center to unit's right side is ④.

⑤ For left side piping, piping connection for liquid should be about ⑤ from this line.  
 ⑥ For left side piping, piping connection for gas should be about ⑥ from this line.

### 3 TO DRILL A HOLE IN THE WALL AND INSTALL A SLEEVE OF PIPING

1. Insert the piping sleeve to the hole.  
 2. Fix the bushing to the sleeve.  
 3. Cut the sleeve until it extrudes about 15 mm from the wall.  
 4. Finish by sealing the sleeve with putty or caulking compound at the final stage.

**CAUTION**  
 When the wall is hollow, please be sure to use the sleeve for tube assembly to prevent dangers caused by mice biting the connection cable.

### 4 INDOOR UNIT INSTALLATION

Do not turn over the unit without shock absorber during pull out the piping. It may cause intake grille damage.  
 Use shock absorber during pull out the piping to protect the intake grille from damage.

#### 1. FOR THE RIGHT REAR PIPING

Step-1 Pull out the Indoor piping  
 Step-2 Install the Indoor Unit  
 Step-3 Secure the Indoor Unit  
 Step-4 Insert the connection cable

#### 2. FOR THE RIGHT AND RIGHT BOTTOM PIPING

Step-1 Pull out the Indoor piping  
 Step-2 Install the Indoor Unit  
 Step-3 Insert the connection cable  
 Step-4 Secure the Indoor Unit

#### Secure the Indoor Unit

1. Power supply cord arrangement  
 2. Press the lower left and right side of the unit against the installation plate until hooks engage with their slot (sound click).  
 3. Press the area of orange color to release holder.

### 3. FOR THE EMBEDDED PIPING

Step-1 Change the drain hose position  
 Step-2 Bend the embedded piping  
 Step-3 Pull the connection cable into Indoor  
 Step-4 Cut and flare the embedded piping  
 Step-5 Install the Indoor Unit  
 Step-6 Connect the piping  
 Step-7 Insulate and finish the piping  
 Step-8 Secure the Indoor Unit

### 5 CONNECT THE CABLE TO THE INDOOR UNIT

1. Install the indoor unit on the installing holder that mounted on the wall.  
 2. Open the front panel and grille door by loosening the screw.  
 3. Connection cable between indoor unit and outdoor unit shall be approved polychloroprene sheathed, 4 x 1.5 mm<sup>2</sup> (1.0 - 1.5HP) flexible cord, type designation 60245 IEC 57 or heavier cord. Do not use joint connection cable. Replace the wire if the existing wire (from concealed wiring, or otherwise) is too short.  
 4. Bind all the indoor and outdoor Connection cable with tape and route the connection cable via the right side escapement.

### 5 REMOVE THE TAPES AND CONNECT THE CONNECTION CABLE BETWEEN INDOOR UNIT AND OUTDOOR UNIT ACCORDING TO THE DIAGRAM BELOW.

6 Secure firmly the connecting cable onto the control board with the holder. Do not overtighten holder screw, as this may damage the holder.  
 7 Close grille door by tighten with screw and close the front panel.

**WARNING**  
 This equipment must be properly earthed.

### WIRE STRIPPING, CONNECTING REQUIREMENT

Wire stripping: No loose strand when inserted.  
 Indoor/outdoor connection terminal board: 5 mm or more (gap between wires).  
 Conductor fully inserted, Conductor over inserted, Conductor not fully inserted.

**RISK OF FIRE**  
 JOINING OF WIRES MAY CAUSE OVERHEATING AND FIRE.  
 Do not joint wires.  
 Use complete wire without joining.  
 Use approved socket and plug with earth pin.  
 Wire connection in this area must follow to national wiring rules.

### 1 SELECT THE BEST LOCATION (Refer to "Select the best location" section)

### 2 INSTALL THE OUTDOOR UNIT

• After selecting the best location, start installation according to Indoor/Outdoor Unit Installation Diagram.  
 • Please mount the outdoor unit on stable ground to prevent vibration and increase of noise level.  
 • Decide the location for piping after sorting out the different types of pipe available.  
 1. Fix the unit on concrete or rigid frame firmly and horizontally by bolt nut (ø8 mm).  
 2. When installing at roof, please consider strong wind and earthquake.  
 CONDENSED WATER DISPOSAL OF OUTDOOR UNIT  
 Please fasten the installation stand firmly with bolt or nails.  
 • There is hole on the base of outdoor unit for condensed water to exhaust.  
 • When connecting the drain hose, it must be below the horizontal line and the drain hose keep smooth, in order to flow condensed water to the drain elbow.

**CAUTION**  
 Install the outdoor unit horizontally or keep the air outlet side higher than the horizontal plane 0 - 2° and make sure that condensate drains away.

### 3 CONNECTING THE PIPING

Connecting Piping to Indoor  
 Connecting Piping to Outdoor

Decide piping length and then cut by using pipe cutter. Remove burrs from cutting edge. Make flare after inserting the flare nut (locate at valve) onto the copper pipe. Align center of piping to valves and then tighten with torque wrench to the specified torque as stated in the table.

Piping size	Torque
6.35 mm (1/4")	118 Nm (1.8 kgf·m)
9.52 mm (3/8")	142 Nm (4.3 kgf·m)
12.7 mm (1/2")	155 Nm (5.6 kgf·m)
15.88 mm (5/8")	165 Nm (6.6 kgf·m)
19.05 mm (3/4")	100 Nm (10.2 kgf·m)

### CUTTING AND FLARING THE PIPING

1. Please cut using pipe cutter and then remove the burrs.  
 2. Remove the burrs by using reamer. If burrs is not removed, gas leakage may be caused. Turn the piping end down to avoid the metal powder entering the pipe.  
 3. Please make flare after inserting the flare nut onto the copper pipes.

### AIR PURGING METHOD IS PROHIBITED FOR R32 SYSTEM

### 4 AIR TIGHTNESS TEST ON THE REFRIGERATING SYSTEM

Do not purge the air with refrigerants but use a vacuum pump to vacuum the installation.  
 There is no extra refrigerant in the outdoor unit for air purging.

• Before system is charged with refrigerant and before the refrigerating system is put into operation, below site test procedure and acceptance criteria shall be verified by the certified technicians, and/or the installer.  
 • Be sure to check whole system for gas leakage.

#### Preparation (Step 1-2)

#### Evacuation (Step 3-4)

#### Tightness Test with Inert Gas (Step 5-7)

#### Recovery of Test Gas (Step 13)

#### Evacuation (Step 3-4)

#### Complete

1) Connect a charging hose with a push pin to the Low side of a charging set and the service port of the 3-way valve. During extremely cold winter, material contraction might happened, try to further tighten the 2-way, 3-way valve to ensure they are fully closed.  
 2) Attach the gauge manifold set correctly and tightly. Make sure that both valves of the manifold gauge (low pressure and high pressure) is in close position.  
 3) Connect the center hose of the manifold gauge to a vacuum pump.  
 4) Turn on the power switch of the vacuum pump, then turn open the low side manifold gauge valve and make sure that the needle in the gauge moves from 0cmHg (0 MPa) to -76 cmHg (-0.1 MPa) or vacuum until 500 microns is achieved. This process continues for approximately ten minutes. Then close the low side manifold gauge valve.  
 5) Remove the vacuum pump from the centre hose and connect the center hose to cylinder of any applicable inert gas as test gas.  
 6) Charge test gas into the system and wait until the pressure within the system to reach min. 1.04MPa (10.4bar).  
 7) Wait and monitor the pressure reading on the gauges. Check if there is any pressure drop. Waiting time depends on the size of the system.  
 8) If there is any pressure drop, perform step 9-12. If there is no pressure drop, perform step 13.  
 9) Use Gas Leak Detector to check for leaks. There is use the detection equipment with a sensitivity of 5 grams per year of test gas or better.  
 10) Move the probe along the air conditioning system to check for leaks, and mark for repair.  
 11) Any leak detected and marked shall be repaired.  
 12) After repair, repeat evacuation steps 3-4 and tightness test steps 5-7. Check the pressure drop as in step 8.  
 13) If no leak, Recover the test gas. Perform evacuation of steps 3-4. Then proceed to step 14.  
 14) Disconnect the charging hose from the service port of the 3-way valve.  
 15) Tighten the service port caps of the 3-way valve at a torque of 6 Nm with a torque wrench.  
 16) Remove the valve caps of both of the 2-way valve and 3-way valve.  
 17) Open both of the valves, using a hexagonal wrench (4 mm).  
 18) It is recommended to allow refrigerant slowly flow into the refrigerant system to prevent refrigerant freezing. Slightly open 2-way valve for 5 seconds then close the valve. Repeat this action for 3 cycles then fully open the valve.  
 19) Mount back the valve caps onto the 2-way valve and the 3-way valve to complete this process.

### 5 CONNECT THE CABLE TO THE OUTDOOR UNIT

1. Remove the control board cover from the unit by loosening the screws.  
 2. Connection cable between indoor unit and outdoor unit shall be approved polychloroprene sheathed 4 x 1.5 mm<sup>2</sup> flexible cord, type designation 60245 IEC 57 or heavier cord. Do not use joint connection cable. Replace the wire if the existing wire (from concealed wiring, or otherwise) is too short.  
 3. Secure the cable onto the control board with the holder (clammer).  
 4. Attach the control board cover to the original position with the screws.  
 5. For wire stripping and connection requirement, refer to instruction ⑤ of indoor unit.  
 • Earth wire shall be Yellow/ Green (Y/G) in color and longer than other AC wires for safety reason.

### 6 PIPING INSULATION

1. Please carry out insulation at pipe connection portion as mentioned in Indoor/Outdoor Unit Installation Diagram. Please wrap the insulated piping end to prevent water from going inside the piping.  
 2. If drain hose or connecting piping is in the room (where dew may form), please increase the insulation by using POLY-E FOAM with thickness 6 mm or above.

### HOW TO TAKE OUT FRONT GRILLE

Please follow the steps below to take out front grille if necessary such as when installing or servicing.  
 1. Open front panel.  
 2. Remove the 3 mounting screws on the front grille as shown in the illustration below.  
 3. Slide the 3 lock knobs on the upside of front grille to unlock position.  
 4. Pull the front grille towards you to remove the front grille.

### AUTO SWITCH OPERATION

The below operations will be performed by pressing the "AUTO" switch.  
 1. AUTO OPERATION MODE  
 The Auto operation will be activated immediately once the Auto Switch is pressed and release within 5 sec.  
 2. TEST RUN OPERATION (FOR PUMP DOWN/SERVICING PURPOSE)  
 The Test Run operation will be activated if the Auto Switch is pressed continuously for more than 5 sec. to below 8 sec...  
 A "peep" sound will occur at the fifth sec., in order to identify the starting of Test Run operation.  
 3. HEATING TRIAL OPERATION  
 Press the "AUTO" switch continuously for more than 8 sec. to below 11 sec., and release when a "pep pep" sound is occurred at eight sec. (However, a "pep" sound is occurred at fifth sec.)  
 Then press Remote controller "AC Reset" button once.  
 Remote controller signal will activate operation to force heating mode.  
 4. REMOTE CONTROLLER RECEIVING SOUND ON/OFF  
 The ON/OFF of Remote controller receiving sound can be change over by the following steps:  
 a) Press "AUTO" switch continuously for more than 16 sec. to below 21 sec...  
 A "pep", "pep", "pep", "pep" sound will occur at the sixteenth sec...  
 b) Press the "AC Reset" button once, "pep" sound will occur indicates that Remote controller receiving sound setting mode is activated.  
 c) Press "AUTO" switch again. Everytime "AUTO" switch is pressed (within 60 sec. interval), Remote controller receiving sound status will be reversed between ON and OFF.  
 Long "peep" sound indicates that Remote controller receiving sound is ON.  
 Short "pep" sound indicates that Remote controller receiving sound is OFF.

### CHECK THE DRAINAGE

• Open front panel and remove air filters. (Drainage checking can be carried out without removing the front grille.)  
 • Pour a glass of water into the drain tray-styrofoam.  
 • Ensure that water flows out from drain hose of the indoor unit.

### EVALUATION OF THE PERFORMANCE

• Operate the unit at cooling/heating operation mode for fifteen minutes or more.  
 • Measure the temperature of the intake and discharge air.  
 • Ensure the difference between the intake temperature and the discharge is more than 8 °C during Cooling operation or more than 14 °C during Heating operation.

### IN CASE OF REUSING EXISTING REFRIGERANT PIPING

Observe the followings to decide reusing the existing refrigerant piping.  
 Poor refrigerant piping could result in product failure.  
 • In the circumstances listed below, do not reuse any refrigerant piping. Instead, make sure to install a new piping.  
 - Heat insulation is not provided for either liquid-side or gas-side piping or both.  
 - The existing refrigerant pipe has been left in an open condition.  
 - The diameter and thickness of the existing refrigerant piping does not meet the requirement.  
 - The piping length and elevation does not meet the requirement.  
 Perform proper pump down before reuse piping.  
 • In the circumstances listed below, clean it thoroughly before reuse.  
 - Pump down operation cannot be performed for the existing air-conditioner.  
 - The compressor has a failure history.  
 - Oil color is darken. (ASTM 4.0 and above).  
 - The existing air-conditioner is gas/oil heat pump type.  
 • Do not reuse the flare to prevent gas leak. Make sure to install a new flare.  
 • If there is a welded part on the existing refrigerant piping, conduct a gas leak check on the welded part.  
 • Replace deteriorated heat insulating material with a new one.  
 Heat insulating material is required for both liquid-side and gas-side piping.

### Proper Pump Down Method

1. Operate air conditioner on cooling mode for 10 - 15 minutes.  
 2. After 10 - 15 minutes of pre operation, close 2 way valve. After 3 minutes, close 3 way valve.  
 3. Take out air conditioner unit.  
 4. Install New Refrigerant air conditioner.

### Most Important Process Purpose

To make the oil & refrigerant mix together. They are in separated condition when air conditioner is stopped.  
 Mixed refrigerant & oil will be collected into outdoor unit.  
 Only very small amount of oil remain inside piping, which is acceptable.

### CHECK ITEMS

Is there any gas leakage at flare nut connections?  
 Has the heat insulation been carried out at flare nut connection?  
 Is the connection cable being fixed to terminal board firmly?  
 Is the connection cable being clamped firmly?  
 Is the drainage ok? (Refer to "Check the drainage" section)  
 Is the earth wire connection properly done?  
 Is the indoor unit properly hooked to the installation plate?  
 Is the power supply voltage complied with rated value?  
 Is there any abnormal sound?  
 Is the cooling/heating operation normal?  
 Is the thermostat operation normal?  
 Is the remote control's LCD operation normal?



# 安裝說明

## 空調器

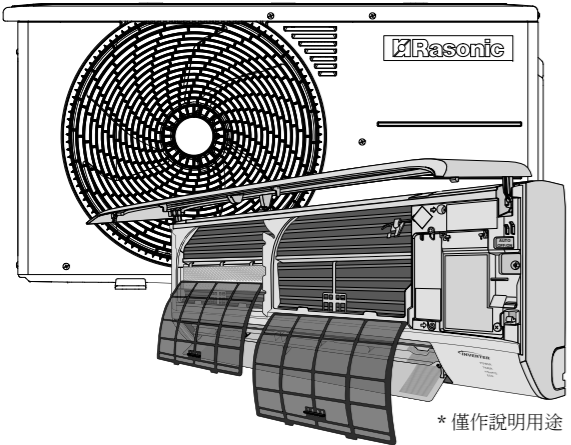

\* 僅作說明用途

型號：**RS/RU-LZ9\*\* (1.0HP)**  
**RS/RU-LZ12\*\* (1.5HP)**

### ⚠ 注意

## R32 冷媒

此空調設備包含 R32 冷媒劑並利用 R32 冷劑進行安裝。

須由具備資質的人員對此產品進行安裝或維修。

對此產品進行安裝、保養或維修之前，請參閱國家、州、地區和地方法律、條例、法規、安裝和調作手冊。

室內機或室外機顯示的符號說明。	
	<b>警告</b> 這符號顯示這個設備使用了一種較容易的冷劑。如果冷劑與室外部點火點一起洩漏，則有可能點燃。
	<b>注意</b> 這個符號表示該仔細閱讀安裝手冊。
	<b>注意</b> 此符號表示檢修人員應參閱“安裝手冊”處理此設備。
	<b>注意</b> 此符號表示操作手冊和或安裝手冊中包含了信息。

### 安全措施

- 安裝之前請詳細閱讀此“安全措施”。
- 電氣工作必須由持證工人安裝。請務必使用有正確額定電壓的插頭與電線。
- 請務必遵照所述注意事項，因為其重要內容與您的安全息息相關。各行號的意義如下。忽視指示造成安裝不當，可能會導致受傷或損壞。其嚴重程度如下所示。

	<b>警告</b> 此符號表示可能導致死亡或重傷。		應遵照的注意事項目以下符號分類。		白色底的符號表示被禁止的項目。
	<b>注意</b> 此符號表示可能只導致受傷或機件損壞。				深色底的符號表示必須進行的項目。

如果將設備轉讓給新用戶或交付給回收工廠，請務必同時轉交手冊。

### 警告

- 除非製造商推薦，否則切勿使用工具加速除霜過程或進行清理。任何不適宜的方法或使用不適當的材料可能導致產品損壞、破裂和嚴重損害。
- 不要將室外機安裝在靠近陽臺的扶手。當在高樓的陽臺安裝空調調節機時，必須注意小孩可能會爬上室外機並取出扶手，繼而導致意外發生。
- 勿使用非指定電纜、改裝電纜、接駁電纜或延長電纜作為電源電纜。勿與其他電器共用一個插頭。接觸不良、絕緣不良或電流超額將導致觸電或火災。
- 切勿用帶子將電源電纜繫成一捆。
- 切勿將您的手指或其他物體插入本機，高速轉動的風扇可能會導致損傷。
- 切勿坐或踩踏在本機上以免意外摔跌。
- 將膠膠袋（包裝材料）遠離小孩，它可能會粘附在鼻子和嘴巴導致窒息。
- 當安裝或重新安裝空調調節機時，除指定冷劑外，勿讓任何物體，例如空氣等，混入製冷循環系統（導管）。空氣等的加入將導致製冷循環系統出現異常高壓並導致爆炸、受傷等等。
- 切勿刺穿或燒燒，因為本設備已加壓。切勿讓本設備接觸高溫、明火、火花或其他點火源。否則，可能發生爆炸，導致受傷或死亡。
- 切勿添加或更換指定類型以外的冷劑。這可能會導致產品損壞、破裂、損傷等。

- 對於 R32/R410A 模型，請使用 R32/R410A 冷劑劑所指定的導管、擴口螺母及工具。使用現有的 (R22) 導管、擴口螺母及工具可能會導致（導管）冷凍周期出現不尋常高壓，並可能造成爆炸和受傷。
- 對於 R32 和 R410A，可使用同樣的室外機側面擴口螺母和工具。
- 由於 R32/R410A 的工作壓力高於冷劑劑 R22 型號的工作壓力，因此建議更換室外機側面的常規導管和擴口螺母。
- 如果不得重新使用導管，請參閱指示“在重新使用現有冷劑劑配管的情況下”
- 使用於 R32/R410A 的銅管厚度必須超過 0.8 mm 千萬不要使用厚度低於 0.8 mm 的銅管。
- 殘油的数量最好低於 40 mg/10 m。
- 備用授權代理商或專人代為安裝。
- 如果用戶自行安裝不正確，將會引起漏水、觸電或火患。
- 製冷系統作業時，應嚴格按照本安裝說明進行安裝。安裝不得法將會引起漏水、觸電或火患。
- 安裝時務請使用所列之附送或指定之配件。否則這將導致本機附近、漏水、火災或觸電。
- 安裝于堅硬和牢固得足以支撐空調調節機之重量的位置。如果堅固度不足或安裝不得法，空調調節機將會掉下和致傷人。
- 應遵循國家法規、法律及本安裝說明手冊進行電氣作業。一定要使用獨立電路和單一出口。若電路容量不夠或電線安裝出錯，會導致觸電或火患。
- 勿使用接駁電纜為室內/室外連接電纜。使用特定的室內/室外連接電纜，請參閱指示 ④ **如何將電纜連接至室內機**，並將室內/室外連接緊密地連接好。夾緊電纜，使外力對端子無效。若銜接和安裝不妥，會導致銜接發熱或產生火患。
- 電線排列須妥當安排，以避免暴露控制板蓋。如果控制板蓋沒有完全地蓋好，它可能會導致火患或觸電。
- 強力建議為此設備安裝靈敏度 30 毫安/0.1 秒或以下的通地線漏電路斷路器 (ELCB) 或殘餘電流裝置 (RCD)，否則，當設備故障或絕緣故障等情況發生時可能會導致觸電或火患。
- 進行安裝時，請在啟動壓縮機前妥善地安裝冷劑劑導管。在沒有安裝冷劑劑導管和將閥設置到開放位置的情況下操作壓縮機將會導致空氣被吸入、製冷循環系統出現異常高壓並導致爆炸、受傷等等。
- 在進行抽氣操作時，請在拆除冷劑劑導管之前關閉壓縮機。在壓縮機正在操作和閥在開放狀態的情況下拆除冷劑劑導管將會導致空氣被吸入、製冷循環系統出現異常高壓並導致爆炸、受傷等等。
- 根據所設定的方法使用扭力扳手緊接接頭螺絲。如果將接頭螺絲鎖得太緊，經過一段時間後，接頭螺絲可能會爆裂和導致冷劑劑洩漏。
- 安裝完畢後，確保沒有冷劑劑洩漏。冷劑劑一旦和火接觸可能會產生有毒氣體。
- 若在操作期間發生冷劑劑洩漏，請立刻進行通風。冷劑劑一旦和火接觸可能會產生有毒氣體。
- 應意識到冷劑劑不得有氣味。

### 8. 充填步驟

- 除規規充填步驟外，應遵循以下要求。
- 使用充填設備時，確保不會出現不同冷劑劑的污染。
- 導管或管應儘量短，以將管道中所包含之冷劑劑的數量減至最小。
- 應依照使用說明書將調壓器存放於適當位置。
- 為系統充填冷劑劑之前，應確保製冷系統正確接地。
- 充填完成時，請為系統添加標識（若無標識）。
- 應務必小心不要過度充填製冷系統。
- 再次充填之前，應使用無氣測試系統的壓力（參閱第 7 部分）。
- 充填完成時，應在通風之前進行抽氣檢查。
- 離開安裝地點之前應進行後續漏氣檢查。
- 充填和排放冷劑劑時，靜電荷可能積累并構成危險情況。
- 在充填/排放之前，應使容器和設備安全接地，在輸送過程中消除靜電，以避免火災或爆炸。

### 9. 停用

- 執行此程式之前，技術人員須十分熟悉本設備及其全部詳情。
- 建議遵循良好作業規範，所有冷劑劑均應安全回收。
- 在執行此項任務之前，應採取冷劑劑機油和冷劑劑回收。
- 開始此項任務之前須關閉供電以供應正常。
- a) 熟悉本設備及其操作。
- b) 確保系統電氣絕緣。
- c) 嘗試此程式之前應確保：
  - 必要時，備有可供使用的擱置裝置，用於擱置冷劑劑鋼瓶；
  - 備有所有個人防護設備并應正確使用；
  - 回收過程始終要在專任人員的監督之下；
  - 回收設備和鋼瓶符合適當的標準。
- d) 如有可能，為冷劑劑系統抽真空。
- e) 若無法抽成真空，則製作絞管，使從系統的各個部分排放冷劑劑。
- f) 在進行回收之前，應確保鋼瓶位於磅秤上。
- g) 啟動回收機并依照說明書進行操作。
- h) 切勿過度充填鋼瓶。（液體充填不超過容積的 80%。）
- i) 切勿超過鋼瓶的最大工作壓力，暫時超過亦不容許。
- j) 當正在充填鋼瓶並完成充裝過程時，應立即將安裝地點拆除鋼瓶和設備并關閉設備上的所有隔離門。
- k) 除非經過清潔和檢驗，否則不得將所回收的冷劑劑充入另一個製冷系統。
- l) 除非經過清潔和檢驗，否則不得將所回收的冷劑劑充入另一個製冷系統。
- 充填或排放冷劑劑時，靜電荷可能積累并構成危險情況。
- 在充填/排放之前，應使容器和設備安全接地，在輸送過程中消除靜電，以避免火災或爆炸。

### 10. 添加標識

- 應為設備添加標識，說明設備已經停用並且冷劑劑已排空。
- 標識應當注明日期并簽名。
- 確保設備上貼有標識，注明設備包含可燃性冷劑劑。

### 11. 回收

- 當出於檢修或停用設備之目的從系統排放冷劑劑時，建議遵循良好作業規範，所有冷劑劑均應安全排放。
- 當將冷劑劑輸送至鋼瓶時，應確保只使用適當的冷劑劑回收設備。
- 應確保備有適當數量的鋼瓶，使於容納整個系統內充填的冷劑劑。
- 待使用之所有鋼瓶被指定用於回收的冷劑劑并為該冷劑劑添加標識（即，用於冷劑劑回收的特殊鋼瓶）。
- 鋼瓶應配有處於正常狀態的洩壓閥和相關關閉閥。
- 為回收鋼瓶抽真空，如有可能，在進行回收之前請回收回收鋼瓶。
- 切勿在回收裝置中混合冷劑劑，尤其不要在鋼瓶中混合冷劑劑。
- 此外，應將每一處經過通風且處於正常狀態的鋼瓶。
- 導管應配有無洩漏快速接頭且處於良好狀態。
- 使用回收機之前，應檢查回收機是否處於正常狀態、已進行正常維護並且任何相關的電氣部件皆已密封，以防冷劑劑洩漏時發生引燃。
- 如有疑問，請諮詢製造商。
- 應使用正確的回收鋼瓶將所回收的冷劑劑退還至冷劑劑供應商處，并提供相關廢棄物轉移說明。
- 切勿在回收裝置中混合冷劑劑，尤其不要在鋼瓶中混合冷劑劑。
- 如欲拆卸回收機或拆卸相關設備，應確保將其排放至可接收水準，確保漏油油中不含可燃性冷劑劑。
- 將相關機件還至供應商之前，應執行抽真空過程。
- 應對壓縮機機體進行電氣加熱，以加速此過程。
- 當從系統中排放壓縮機機油時，應安全進行。

### 安裝時所需的工具

1 菲力螺絲起子	6 剪管器	11 溫度計	16 扭力扳手
2 水平儀	7 擴孔器	12 高阻表	18 N•m (1.8 kgf•m)
3 電鑽，空心鑽（直徑 Ø70 mm）	8 刀	13 萬用電表	42 N•m (4.3 kgf•m)
4 六角扳手 (4 mm)	9 漏氣偵查器	14 真空泵	55 N•m (5.6 kgf•m)
5 扳手	10 帶尺	15 量規管	65 N•m (6.6 kgf•m)
			100 N•m (10.2 kgf•m)

### 注意

- 勿將空調調節機安裝於易燃氣體可能滲漏之處。氣體洩漏和積存於空調調節機周圍可能會引起火患。
- 防止液體或蒸汽進入污水坑或下水道，因為蒸汽比空氣重，可能形成窒息氣氛。
- 進行喉管工作、重新安裝和維修冷劑劑時不要取出冷劑劑。
- 小心處理液體製冷劑，它可能會導致凍傷。
- 請勿安裝本裝置於洗衣房或其他有水自天花板等滴落之處。
- 切勿觸摸尖銳的鋸齒片以免受到尖銳部件傷害。

### 注意

- 依照安裝說明書安裝排水管。
- 排水管若安裝不當，水滴可能會弄濕房間和損壞家具。
- 選擇容易進行維修工作的安裝位置。此空調調節機安裝、檢修或維修不當可能增加破裂的風險，因而可能導致損失、損壞或受傷或財物損失。
- 室內空調調節機的電源銜接。請使用電線線 3 x 1.5 mm<sup>2</sup> (1.0 - 1.5HP) 類型名稱 60245 IEC 57 或更粗的電線線。用以下其中一種方法將空調調節機的電源電纜連接到總線。電線應該位於容易接近的地方以便在發生緊急事態時可以容易地切斷電源。
- 某些國家禁止空調調節機永久銜接電源供應。
  - 用電插頭插入插孔以銜接電源。
    - 用有地線的合格 15/16A (1.0 - 1.5HP) 電插頭插入插孔以連接電源。
    - 將電源永久銜接到電流切割器。
  - 用合格 16A (1.0 - 1.5HP) 電流切割器進行永久 連接，而且至少有 3.0 mm 空隙的雙極開關。
- 安裝工作。安裝工作可能動用兩人。
- 確保所有通風口保持暢通無阻。

### 使用 R32 冷劑劑注意事項

- 請密切注意以下幾點和安裝工作程序。

### 警告

- 本設備應儲存、安裝并工作於通風良好的空間內，室內面積大於 A<sub>min</sub> (參見表 A) 並且不存在任何連續操作的點火源。遠離明火、任何工作中的燃氣設備或任何工作中的電熱器。否則，可能發生爆炸，導致受傷或死亡。
- 禁止在系統內混合不同的冷劑劑。為安全起見，使用 R32 和 R410A 冷劑劑的型號具有不同的充填端口螺紋直徑，以防錯誤充填 R22 冷劑劑。因此，應專事檢查。[R32 和 R410A 的充填端口螺紋直徑為 12.7 mm (1/2 英寸)。]
- 確保無異物（油、水等）進入導管。
- 而且，當儲存導管時，應通過夾緊、黏貼等方式緊密封閉管口。（R32 之操作與 R410A 相似。）
- 操作、維護、修理以及冷劑劑回收應根據製造商的建議，由使用可燃性冷劑劑方面經過培訓和認證的人員處理。在設備的系統或相關部分上進行操作、維修或維護的任何人員都應該經過培訓和認證。
- 製冷迴路（蒸發器、空氣調節器、AHU、冷凝器或液體接收器）或管路的任何部位不應位於熱源、明火、操作燃氣器具或工作中的電熱器附近。
- 用戶/所有者或授權代表應按照國家規定的要求，至少定期每半年檢查一次報警器、機械通風器和探測器並確保其正確運作。
- 應該保持日記更新。檢查結果應記錄在日記中。
- 應檢查佔用空間內的通風情況，並確認沒有障礙物。
- 在使用新的製冷系統前，負責系統運行者應確保經過培訓和認證的操作人員根據說明手冊對冷劑劑系統進行施工、監理、運行和維護，以及遵守所有安全措施，以及所使用的冷劑劑的特性和處理。
- 培訓和認證人員的一般要求如下：
  - 了解有關可燃性冷劑劑的立法、法規和標準，以及；
  - 擁有有關可燃性冷劑劑、個人防護設備、防止冷劑劑洩漏、處理鋼瓶、充電、洩漏偵測、回收和處置方面的詳細知識和技能，以及；
  - 理解有關國家立法、法規和標準的要求，以及；
  - 持續進行定期和進一步的培訓，以確保持續持有專業知識。
- 應妥善安裝佔用空間內的空調調節管道，以免操作和維修時造成意外損壞。
- 應採取措施避免冷劑劑導管發生過度振動或跳動。
- 應為保護裝置、製冷管道和配件提供良好保護，使其免受不良環境影響（例如，排水管積水和凍結風險或污物和碎屑積堆風險）。
- 製冷系統長管段的膨脹與收縮應妥善設計並安裝平閘（安裝安裝和保護），盡可能將液體衝擊對系統造成損壞的可能性降至最低。
- 應妥善保護製冷系統，避免因移動家具或重建活動等而發生意外破裂。
- 應對室內整體牆面製冷管管接頭進行氣密性測試，確保無洩漏。在至少 0.25 倍於最大容許壓力的壓力 (>1.04MPa，最大 4.15MPa) 下，該測試方法應具備有每年 5 克製冷劑劑或更好的靈敏度。不應洩漏到洩漏。

### 附送之配件

編號	附件	數量	編號	附件	數量																
1	安裝板	1	6	遙控器支架固定螺絲	2																
2	安裝板固定螺絲	5	7	排水盤	1																
3	遙控器	1	8	排水彎管	1																
4	電池	2	<table border="1" style="width: 100%; border-collapse: collapse;"> <tr> <th colspan="2">適用的導管套件</th> <th colspan="2">配管尺寸</th> </tr> <tr> <td></td> <td></td> <td>氣體</td> <td>液體</td> </tr> <tr> <td>CZ-3F5, 7BP</td> <td>9.52 mm (3/8")</td> <td>9.52 mm (3/8")</td> <td>6.35 mm (1/4")</td> </tr> <tr> <td>CZ-4F5, 7, 10BP</td> <td>12.7 mm (1/2")</td> <td>12.7 mm (1/2")</td> <td>6.35 mm (1/4")</td> </tr> </table>			適用的導管套件		配管尺寸				氣體	液體	CZ-3F5, 7BP	9.52 mm (3/8")	9.52 mm (3/8")	6.35 mm (1/4")	CZ-4F5, 7, 10BP	12.7 mm (1/2")	12.7 mm (1/2")	6.35 mm (1/4")
適用的導管套件		配管尺寸																			
		氣體	液體																		
CZ-3F5, 7BP	9.52 mm (3/8")	9.52 mm (3/8")	6.35 mm (1/4")																		
CZ-4F5, 7, 10BP	12.7 mm (1/2")	12.7 mm (1/2")	6.35 mm (1/4")																		
5	遙控器支架	1	附件：擴口管一套 CZ-4F5, 7, 10AN																		

### 選擇最佳位置

室內機	室外機
<ul style="list-style-type: none"> <li>切勿將機組安裝到煙道多的區域，如：廚房、車間等。</li> <li>機組附近應沒有任何熱源或蒸氣。</li> <li>不應有任何阻擋空氣流通的障礙物。</li> <li>最好安裝于空氣流通的地方。</li> <li>最好安裝于可輕鬆完成排水的地方。</li> <li>切勿將機組安裝在靠近門道的地方。</li> <li>切勿將機組安裝在靠近門道的地方。</li> <li>確保前部所示之部位離開牆壁、天花板、簾幕或其他阻礙物一段距離。</li> <li>若導管長度超過（附加氣體的導管長度），則必須如（表 A）所示添加額外的冷劑劑。</li> <li>本空調機室內機最低安裝高度應為 1.8 m。</li> </ul>	<ul style="list-style-type: none"> <li>如果這一個天棚保護室外機以防止陽光直射或雨淋時，則應注意冷卻器的散熱不受阻礙。</li> <li>安裝場所不要與動物和種植物太近，因為排出的熱氣對它們有影響。</li> <li>確保前部所示之部位離開牆壁、天花板、簾幕或其他阻礙物一段距離。</li> <li>不要置放可能會導致散熱空氣受阻的任何障礙物。</li> <li>若導管長度超過（附加氣體的導管長度），則必須如（表 A）所示添加額外的冷劑劑。</li> <li>本空調機室內機最低安裝高度應為 1.8 m。</li> </ul>

### 表 A

型號	容量 W (HP)	配管尺寸	標準長度 (m)	最大高度 (m)	最小管子長度 (m)	最大管子長度 (m)	補充冷劑劑 (g/m)	附加氣體所需的導管長度 (m)	最大冷劑劑充填量 (kg)	A <sub>min</sub> (m <sup>2</sup> )
LZ9**	1.0HP	9.52 mm (3/8")	6.35 mm (1/4")	5	1	15	10	7.5	0.68	不適用 (*)
LZ12**	1.5HP	12.7 mm (1/2")	12.7 mm (1/2")	5	1	15	15	7.5	0.95	不適用 (*)

備用：對於 LZ9\*\*

若機組的安裝距離是 10 m，額外冷劑劑的數量應該是

⇒ 10 m (距離) - 7.5 m (附加氣體的導管長度)

⇒ 2.5 m

⇒ 2.5 m x 10 g/m (附加冷劑劑) ⇒ 25 g

(\*) = 總冷劑劑充填量 m<sub>tot</sub> 低於 1.84 kg 的系統不受任何房間面積要求限制。

**A<sub>min</sub> = (m<sub>tot</sub> / (2.5 x (LFL)<sup>0.66</sup> x h<sub>0</sub>))<sup>2</sup>** \*\* 不小於安全係數

A<sub>min</sub> = 所需最小房間面積 (m<sup>2</sup>)

m<sub>tot</sub> = 設備內冷劑劑充填量 (kg)

LFL = 燃燒下限 (0.307 kg/m<sup>3</sup>)

h<sub>0</sub> = 設備的安裝高度：（壁掛式 1.8 m）

SF = 安全係數值 0.75

\*\* 所需最小房間面積 A<sub>min</sub> 還應遵循下方的安全係數公式：

**A<sub>min</sub> = m<sub>tot</sub> / (SF x LFL x h<sub>0</sub>)** 確定房間面積時應取較大值。

- 為實現良好通風，障礙方向最好不多於兩個。
- 安裝環境若有三處牆壁障礙（頂部、左邊和右邊），請確保機身的左邊或頂部距離必須是 200 mm 或以上。

200 mm 以上

100 mm 以上

50 mm 以上

100 mm 以上

200 mm 以上

以上任何一種安裝模式的左邊或頂部高度必須是 200 mm 或以上。

### 注意

1. 一般

- 必須確保管件的安裝應保持在最低限度。避免使用凹進的管道，不容許存在銳角彎曲。
- 必須確保管件免受實體損傷。
- 必須遵循國家法規、地方法規和州法律。
- 應依照所有適用法規通知有關當局。
- 必須確保機體連接於進口處。
- 若機體機體連接於進口處，則進口處不應存在障礙物。
- 當置裝此產品時，務必遵循第 1 部分中的注意事項并遵循國家法規。
- 由不同管徑長度造成的冷劑劑充注必須量化的、測量和標記。始終應聯繫當地市政廳，以確保適當操作。
- 確保實際冷劑劑充填量符合冷劑劑部分所安裝之空間的大小而定。
- 確保冷劑劑充注不漏滴。
- 倘若條件允許，應佩戴適當的防護設備，包括呼吸防護器。
- 應遠離所有點火源和熱金屬表面。

### 2. 檢修

2-1. 工作人員資格

- 參與冷劑劑迴路工作或介入冷劑劑迴路的任何具備資質的人員均應持有由行業認可之評估機構頒發的當前有效憑證，該評估機構授權他們有能力依照業內公認的評估規範安全操作冷劑劑。
- 必須按照設備製造商的建議進行檢修。需要其他熟練技術人員協助的保養和維修工作應當在能夠勝任可燃性冷劑劑使用的人員之監督下進行。
- 必須按照製造商的建議進行檢修。
- 系統由受僱於該用戶或負責人的經過培訓和認證的檢修人員進行進行檢查、定期監督和維護。

2-2. 檢查該區域

- 開始在包含可燃性冷劑劑的系統上作業之前，必須進行安全檢查，以確保將引燃之風險降至最低。對製冷系統進行維修時，開始在系統上作業之前，必須遵循第 2-3 部分至第 2-7 部分的注意事項。

2-3. 作業程序

- 應按照可控的程式進行作業，以便將工作期間存在可燃氣體或蒸汽的風險降至最低。

2-4. 一般作業區域

- 應當將所進行作業之性質告知該區域內作業的所有維護人員和其他人員并予以監督。
- 避免在局限空間內作業。務必確保遠離源頭至少 2 米的安全距離，或半徑至少半徑 2 米的自由空間區域。

2-5. 檢查是否存在冷劑劑

- 在作業之前及作業過程中，應使用適當的冷劑劑偵測器檢測該區域。確保技術人員知曉潛在的易燃空氣。
- 確保所使用的洩漏偵測設備適用於可燃性冷劑劑，即，無火花、充分密封或本質安全。
- 如果發生洩漏/溢漏，應立即為該區域進行通風，保持逆風并遠離洩漏/溢漏。
- 如果發生洩漏/溢漏，應通知洩漏/溢漏順風方向之人員，立即隔離危害區域，非授權人員不得進入該區域。

2-6. 備有滅火器

- 若要在製冷設備或任何相關零件上進行任何高溫作業，應確保適當的滅火設備隨時可供使用。
- 充填區域附近應配置乾粉滅火器或 CO<sub>2</sub> 滅火器。

2-7. 無點火源

- 進行製冷系統（涉及暴露包含可燃性冷劑劑的任何管件）相關之作業的任何人員均不得使用任何點火源，因為這可能導致火災。
- 應採取措施，該人員進行此類作業時嚴禁吸煙。
- 包括吸煙在內的所有可能之點火源均應足夠距離安裝、維修、拆卸和處理區域，因為在這些作業期間，可燃性冷劑劑可能被排放至周圍環境中。
- 進行作業之前，應檢查設備周圍區域，確保不存在任何易燃危險或點火風險。
- 應設置“禁止吸煙”標誌。

2-8. 通風區域

- 介入該系統或應進行任何高溫作業之前，應確保該區域寬敞或充分通風。
- 進行作業期間應保持一定的通風。
- 通風應當能夠安全分散任何洩漏的冷劑劑，最好將其驅散至外部環境中。

2-9. 製冷設備檢查

- 更換電氣部件時，該電氣部件應符合預期用途并具備正確的規格。
- 始終應遵循製造商的保養和檢修規範。
- 如有疑問，請諮詢製造商的技術部門獲取協助。
- 以下檢查應適用於使用可燃性冷劑劑的安裝。
  - 實際冷劑劑充填量符合冷劑劑部分所安裝之空間的大小而定。
  - 通風機器和出口口正常工作且不存在障礙物。
  - 如果使用間接製冷迴路，應檢查二次迴路是否存在冷劑劑。
  - 設備標記清晰可見、易辨認。應更正標記錯誤的標記和標誌。
  - 冷劑劑導管或部件不應安裝於可能使冷劑劑部件暴露于任何存在腐蝕物質的位置，除非這些部件由本質上耐蝕材料製成或者得到適當的防腐蝕保護。

### 室內/室外裝機圖

電源電線長度 約 650 mm

約 1550 mm

導管方向 (正面)

右 右後 右前 左後 左前 左

注意不要將排水管向上彎曲

顧客應購買的安裝零件 (X)

安裝板 (X)

套管 (X)

套管襯套 (X)

油灰 (X) (粘膠型密封劑)

導管管線，使其盡可能貼近牆面，但小心別弄斷它。

電纜電纜 (X)

纖維尼龍膠帶 (寬) (X)

包裝之前先進行排水試驗。

進行排水試驗時，取下空調機，將水倒入熱交換器。

電纜固定座 (X)

注意

- 安裝好管子和電纜連接之後，請確保安裝排水盤。
- 排水盒安裝不當可能會導致漏水。
- 擰開機殼側板上的 2 枚螺絲，然後用螺絲固定排水盤。

本安裝圖僅用於說明目的。

ACXF60-49770 (1/2)

在馬來西亞印刷

### 1 選擇最佳位置 (參考“選擇最佳位置”之頁)

### 2 如何固定安裝板

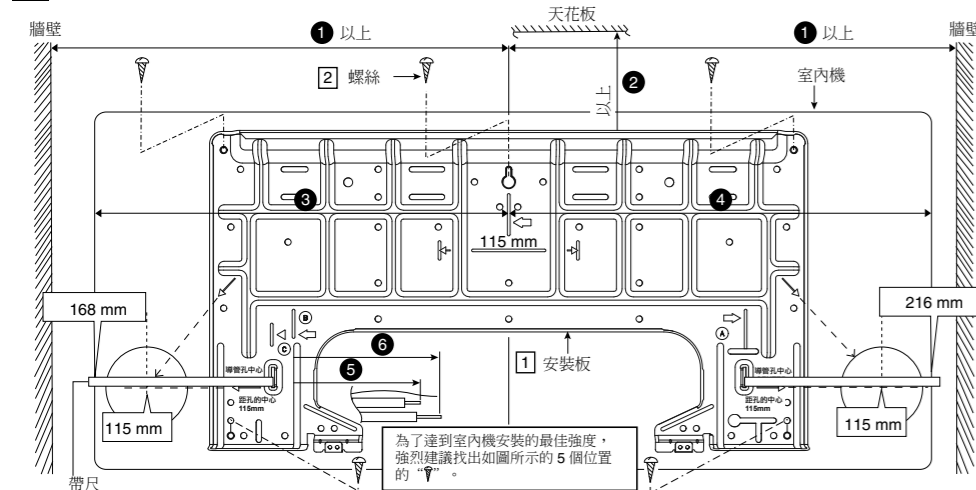

- 安裝板的中心點到左及右邊牆的距離應大於①。
- 從安裝板邊緣到天花板的距離應大於②。
- 從安裝板中心到本機的左側為③。
- 從安裝板中心到本機的右側為④。

**尺寸②**  
(+) : 如要使用機箱後部的支架 (請參閱“4 室內機的安裝”一欄) 來支撐機組, 則該距離應為 85 mm 或以上。

- 至於左邊導管, 從這條線起至液體導管連接的距離應約為⑤。
- 至於右邊導管, 從這條線起至氣體導管連接的距離應約為⑥。

1. 用 5 枚或以上的螺絲 (至少 5 枚螺絲), 將安裝板安裝到牆面上。 (如果將機組安裝到混凝土牆面上, 可考慮使用錨定螺絲)。
2. 務必使用水平儀及細線標記一道劃線, 並通過對準該道劃線, 以水平方向安裝安裝板。

### 3 在牆上鑽孔及安裝導管套管

1. 將導管套管插入孔中。
2. 為套管裝上機套。
3. 切斷套管, 讓牆外側留下約 15 mm 長的套管。

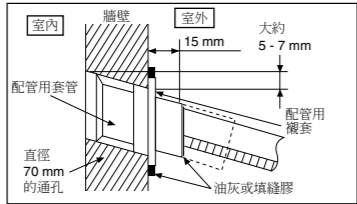

- 當牆壁為空心結構時, 務請使用配管套管, 以防止老鼠咬壞連接電纜而導致的危險。

4. 最後請用油灰或堵窩劑加密封 (在最後階段進行)。

### 4 室內機的安裝

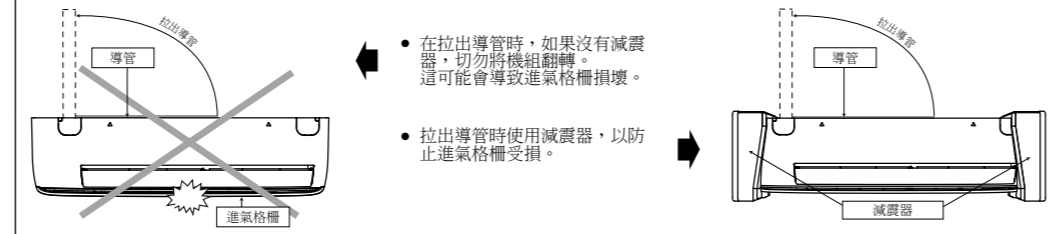

#### 1. 右後導管的安裝

1. 拉出室內導管
2. 安裝室內機
3. 固定室內機
4. 插入連接電纜

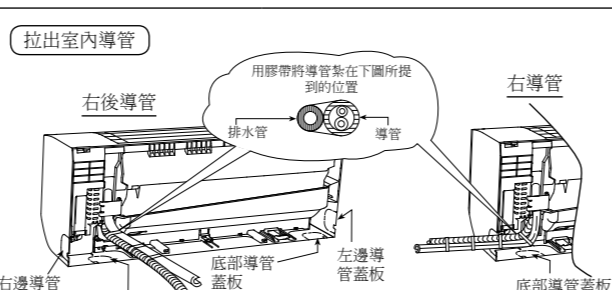

#### 2. 右邊和右下導管的安裝

1. 拉出室內導管
2. 安裝室內機
3. 插入連接電纜
4. 固定室內機

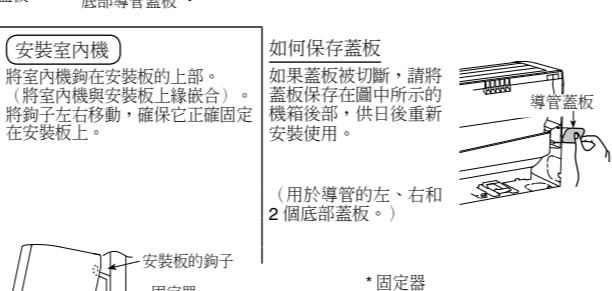

#### 固定室內機

1. 電源電纜整理多餘的電源電纜應該被整理好收在機身後方的導管上, 如圖所示, 並不是扎成一束。
2. 請確保電源電纜沒有被夾夾於主機的掛鉤 (2 個位置) 和安裝板之間。
3. 確定連接電纜沒有在機身和安裝板之間被拉緊。
4. 這可能會產生刺耳的聲音。



#### 欲取出機組, 請按下列機組底座的▽標記, 並朝自己方向稍稍拉出, 以鬆開機組的鉤子。

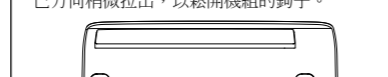

#### 插入連接電纜



### 3. 嵌入式配管的處理

1. 更改排水管的位置
2. 將嵌入式導管弄彎
3. 引導連接電纜進入室內機
4. 切割和擴大嵌入式導管
5. 安裝室內機
6. 連接管子
7. 為導管進行隔熱及成型處理
8. 固定室內機

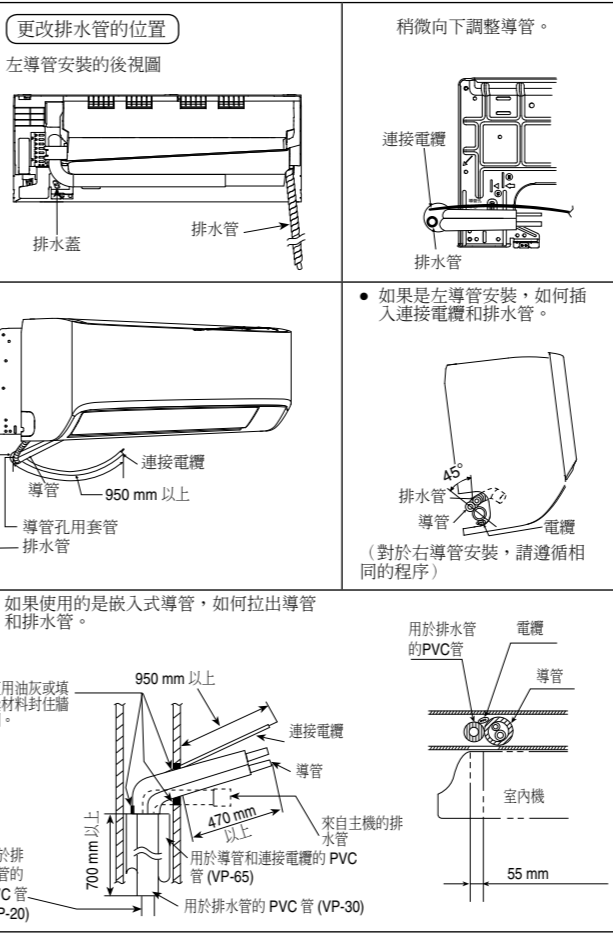

### 5 將電纜連接至室內機

1. 將室內機安裝在裝在牆壁上的安裝支架。
2. 鬆開螺絲然後打開前面板和格柵門。
3. 室內和室外的連接電纜應採用被批准的聚氯丁二烯雙綫裝。4 x 1.5 mm<sup>2</sup> (1.0 - 1.5HP) 電線 (編號 60245 IEC 57) 或負荷更高的電線。切勿使用接駁連接電纜。
4. 用膠帶綁起所有室內機和室外機的連接電纜, 並將連接電纜繞至左邊出口。

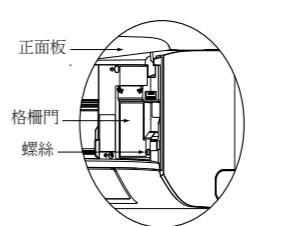

### 5 將電線連接至室外機

1. 旋松螺絲以取下控制板蓋。
2. 室內和室外的連接電纜應採用合格的 4 x 1.5 mm<sup>2</sup> 聚氯丁稀鍍裝電線 (編號 60245 IEC 57), 或負荷更高的電線。切勿使用接駁連接電纜。
3. 若現有 (隱藏配線或其它) 電纜太短, 請更換之。
3. 用固固件 (夾扣) 把電纜牢牢地固定在控制板上。
4. 以螺絲將控制板蓋安裝回原來的位。
5. 欲瞭解割線和連接要求, 請參閱室內機的說明書。
6. 基於安全理由, 地線應該是黃色/綠色 (Y/G) 以及較其他交流電線長。

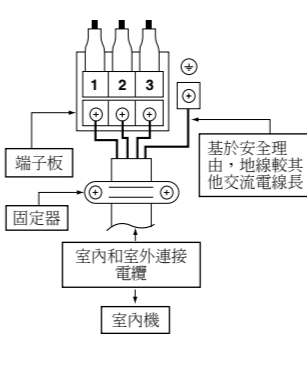

### 6 喉管絕緣

1. 請如室內/室外機安裝圖所示在配管連接部分進行絕緣。
2. 請將已絕緣的管子末端包好, 以防止水流進管子內。

### 如何取出前格柵

1. 打開前面板, 然後取出空氣過濾器。
2. 排水檢查可在不卸下前格柵的情況下進行。
3. 排水托架的發泡膠倒置一杯水。
4. 確保水從室內的排水管流出。

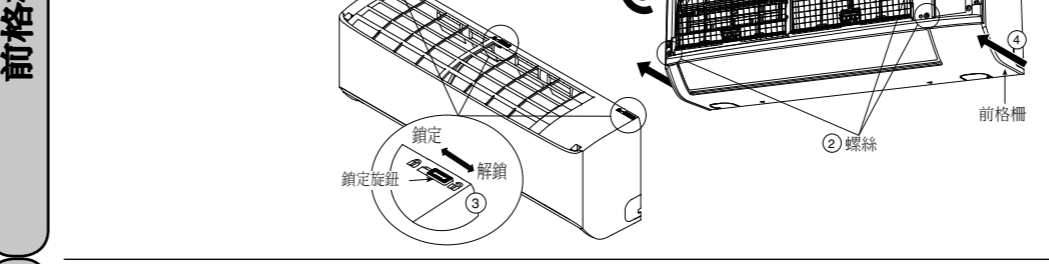

### 自動開關操作

1. 自動操作模式
  - 一旦按下“自動開關”按鈕並在 5 秒之內鬆開, 自動操作將立即生效。
2. 試運轉操作 (用於抽氣/檢修目的)
  - 如果持續按自動按鈕 5 至 8 秒鐘, 試運轉操作將被激活。
  - “噁”聲在第五秒時會響起, 以顯示測試已開始操作。
3. 制熱測試操作
  - 持續按“AUTO”按鈕 8 至 11 秒鐘, 然後在第八秒鐘聽到“噁噁”聲響時鬆開 (請注意在第五秒鐘時會發出“噁”聲響)。
  - 然後按遙控器“AC Reset”按鈕一次。
4. 遙控器接收器的開關
  - 遙控器接收器的開關可按下列步驟更改:
  - a) 持續按“AUTO”按鈕 16 至 21 秒鐘。
  - b) 在第十六秒鐘時會發出“噁”、“噁”、“噁”、“噁”聲響。
  - c) 按下“AC Reset”按鈕一次, 您將會聽到“噁”聲, 表示遙控器接收器設定模式已被開啟。
  - d) 再按“AUTO”按鈕。每次 (在 60 秒的間隔內) 按“AUTO”鈕, 遙控器的接收器聲響狀態將在開和關之間轉換。
  - e) 較長的“噁”聲表示遙控器的接收器聲響設定已被關閉。
  - f) 較短的“噁”聲表示遙控器的接收器聲響設定已被關閉。

### 1 選擇最佳位置 (參考“選擇最佳位置”之頁)

### 2 裝置室外機

- 選定最佳位置後, 依照室內/室外機安裝圖進行安裝。
- 請將室外機安裝在平穩的地面, 以防震動及噪聲級別增加。
- 在挑選出可用的不同的管線後, 決定導管位置。
- 1. 用螺絲 (ø8 mm) 將室外機穩實打穩地裝在牆上或板面上。
- 2. 若裝在屋頂, 請考慮到強風和地震。

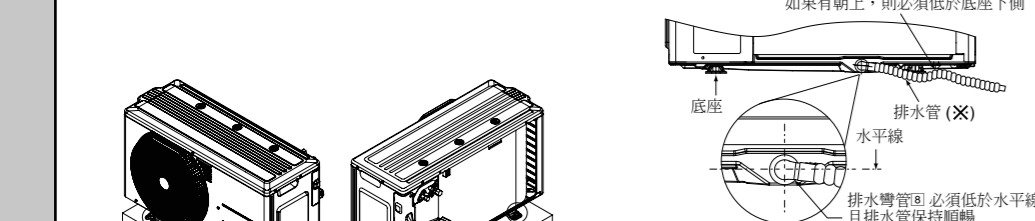

- 室外機底座有孔, 供風扇水排出。
- 當連接排水管時, 其必須須於水平線下方並且排水管保持順暢, 為了讓廢水能流至排水管。

### 3 連接管子

1. 確保在連接到機台前管道道的重新燃燒, 以避免洩漏
2. 使用中性固化的 (烷氧基型), 無氣硅酮密封膠和隔熱材料充分密封接口螺母 (氣體和液體側管), 以免因凍結而造成氣體洩漏。
3. 沿圓周方向施力塗抹中性固化的 (烷氧基型), 無氣硅酮密封膠於連接處的外圍。
4. 目的在於避免水分進入連接處, 進而可能發生凍結。
5. 密封膠固化的時間需要一段時間。
6. 包裹隔熱材料時應確保密封膠不會剝落。

配管尺寸	轉矩
6.35 mm (1/4")	18 Nm (1.8 kgfcm)
9.52 mm (3/8")	142 Nm (14.2 kgfcm)
12.7 mm (1/2")	155 Nm (15.5 kgfcm)
15.88 mm (5/8")	155 Nm (15.5 kgfcm)
19.05 mm (3/4")	100 Nm (10.2 kgfcm)

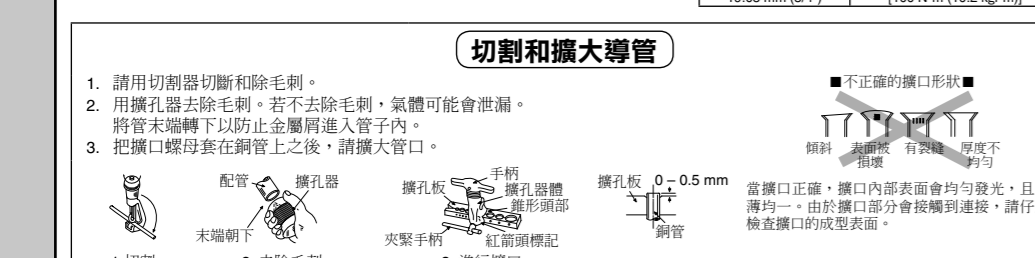

### 4 製冷系統氣密測試

- 切勿使用冷凍劑排除系統內的空氣, 而應使用真空泵為裝置抽真空。
- 1. 室外機內不存在額外冷劑用於排除空氣。
- 在為系統安裝冷劑之前以及製冷系統投入工作之前, 應由經認證的技術人員和/或安裝工對下方現場測試程序和驗收準則予以核實。
- 請務必檢查整個系統是否存在氣體洩漏。

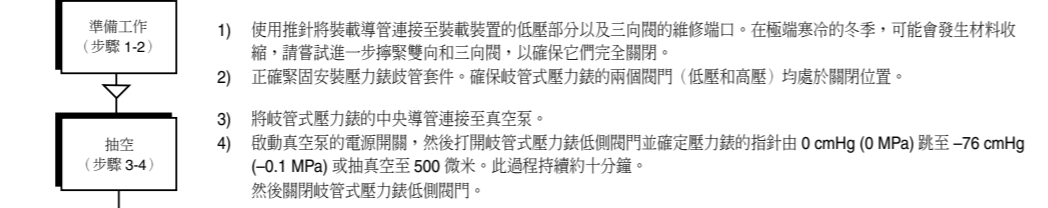

- 1) 使用推針將裝載導管連接至裝載裝置的低壓部分以及三向間的維修端口。在極端寒冷的冬季, 可能會發生材料收縮, 請嘗試進一步擰緊雙向和三向間, 以確保它們完全關閉。
- 2) 正壓固定安裝壓力錶裝置套件, 確保管式壓力錶的兩個閘門 (低壓和高壓) 均處於關閉位置。
- 3) 將較管式壓力錶的中央導管連接至真空室。
- 4) 啟動真空室的電源開關, 然後打開較管式壓力錶低壓閘門並確定壓力錶的指針由 0 cmHg (0 MPa) 跌至 -76 cmHg (-0.1 MPa) 或抽真空至 500 微米。此過程持續約十分鐘。然後關閉較管式壓力錶低壓閘門。
- 5) 從中央管線上拆下真空室並將中央導管與任何通用作為測試氣體的惰性質氣體鋼瓶相連。
- 6) 為系統充填測試氣體並等待系統內的壓力達到 1.04MPa (10.4 bar)。
- 7) 等待并監測壓力錶上的壓力讀數。檢查是否存在壓降。等待時間取決於系統尺寸。
- 8) 若存在壓降, 請執行步驟 9-12; 若不存在壓降, 請執行步驟 13。
- 9) 使用漏氣偵測器檢查是否存在洩漏。須使用具有每年 5 克測試氣體或更好靈敏度的洩漏偵測設備。
- 10) 沿著空氣調節器系統移動探針, 檢查是否存在洩漏, 并予以標記, 方便維修。
- 11) 應對所偵測和標記的任何洩漏予以維修。
- 12) 維修之後, 重複抽真空步驟 3-4 以及氣密測試步驟 5-7。按照步驟 8 檢查是否存在壓降。
- 13) 若無洩漏, 回收測試氣體。執行抽真空步驟 3-4。然後繼續步驟 14。
- 14) 拆除連接至三向間的維修端口的裝載導管。
- 15) 使用轉矩扳手以 18 Nm 的轉矩將三向間的維修端口蓋子關閉。
- 16) 打開雙向間和三向間的閘蓋。
- 17) 使用六角扳手 (4 mm) 打開兩個閘門。
- 18) 建議讓冷劑緩緩流入冷劑系統, 以防止冷劑凍結。稍稍打開閘門 5 秒鐘, 然後關上閘門。重複此操作 3 次, 然後完全打開閘門。
- 19) 將閘蓋安裝回雙向間和三向間上, 完成此過程。

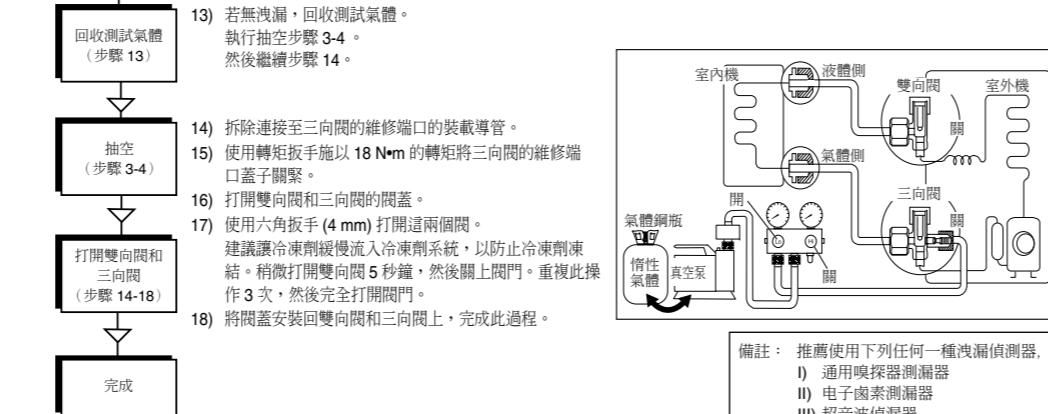

### 5 如下圖所示, 移除膠帶及連接室內機和室外機之間的連接電纜。

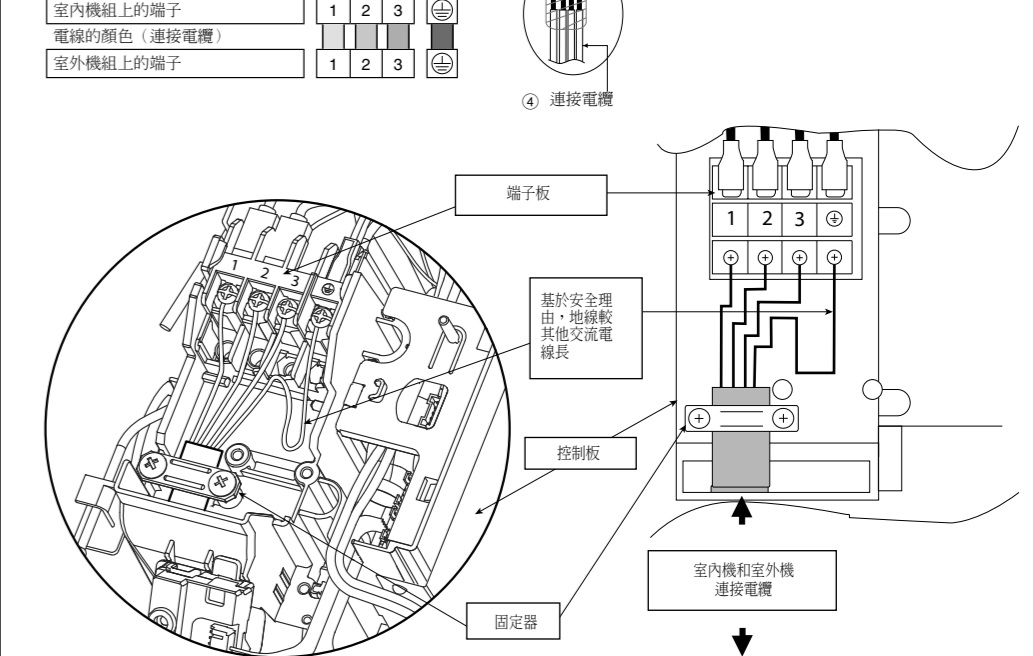

- 絕緣裝置 (用作切斷電路) 必須有至少 3.0 mm 的接觸間隙。
- 確保室外機及室內的電線顏色與室內機相符。
- 為電氣安全起見, 地線的顏色應該如圖所示是黃色/綠色 (Y/G) 比其他交流電線長, 以防電線拖力其固定位置。

6. 用固固件把連接電纜牢牢地固定在控制板上。請勿過度擰緊固定器固定螺絲, 否則可能會損壞固定器。
7. 關上格柵門, 鎖緊螺絲然後關上前面板。

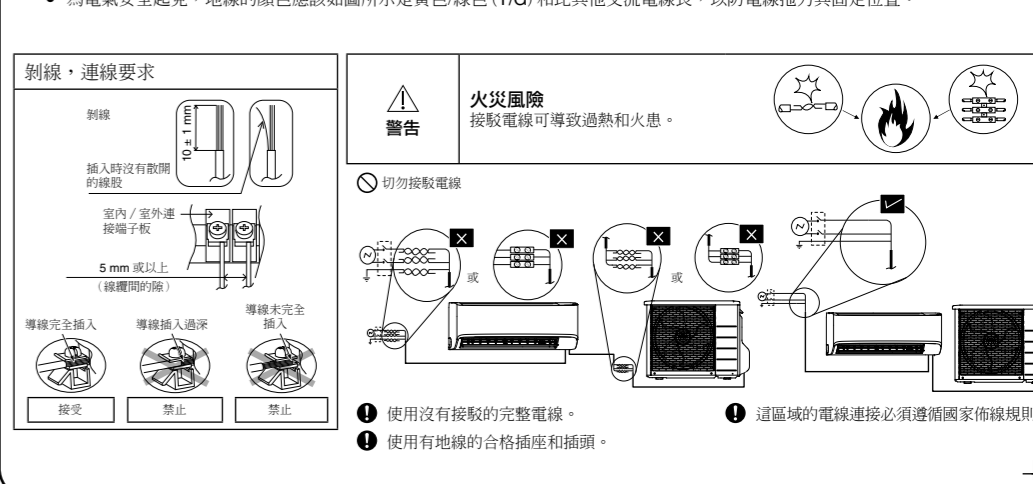

### 檢查排水

- 打開前面板, 然後取出空氣過濾器。
- 排水檢查可在不卸下前格柵的情況下進行。
- 排水托架的發泡膠倒置一杯水。
- 確保水從室內的排水管流出。

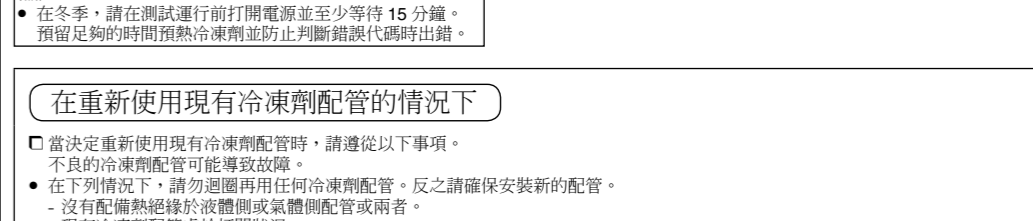

### 性能評估

- 在製冷/制熱操作模式下運轉機組十五分鐘或更長的時間。
- 測量進氣和排氣溫度。
- 確保進氣和排氣之間的溫差在制冷操作模式下超過 8 °C, 而在制熱操作模式下則是超過 14 °C。

- 在製冷模式下運轉空氣調節器 10 - 15 分鐘。
- 操作 10 - 15 分鐘過後, 關閉雙向閘, 3 分鐘過後, 關閉三向閘。
- 取出空氣調節器機組。
- 安裝新的冷劑劑。

